

ADS-VNAPC8PC3

3.5mm NMD jack to 3.5mm plug
34.5GHz VSWR 1.2

50Ω

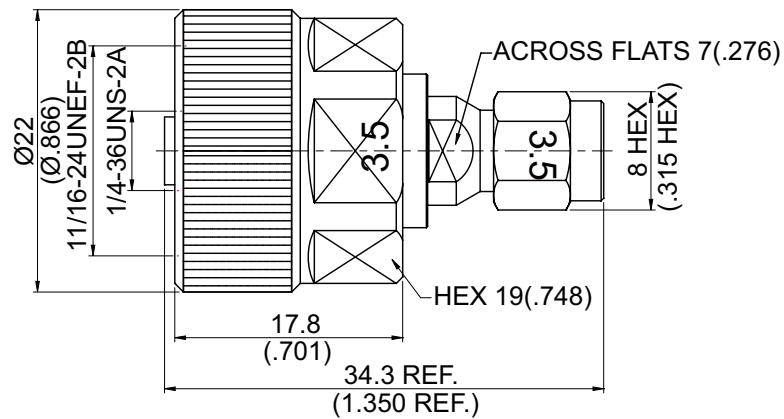

Note: NMD 3.5 Jack to be mounted directly on vector network analyser.

Parts	Material	Plating (Micro-inch)
Retainer Ring	Beryllium Copper	Tin-Zinc-Copper-Alloy 100 Over Copper 50
Gasket	Silicone	
Contact Pin	Beryllium Copper	Gold 4 Over Nickel-Phosphorus Alloy 80 Over Copper 20
Insulator	PEI	
Body	Stainless Steel	Passivated
Coupling Nut	Stainless Steel	Passivated

Weight:

This part number complies with RoHS.

Notice: JYEBAO reserves the right to make modifications deemed appropriate.

ADS-VNAPC8PC3	3.5mm NMD jack to 3.5mm plug 34.5GHz VSWR 1.2
<div data-bbox="129 344 531 394" style="border: 1px solid black; padding: 2px;">Interface</div> <p data-bbox="129 405 986 483">Standard IEC60169-23 Mechanically compatible with 2.92 & SMA</p>	
<div data-bbox="129 607 531 656" style="border: 1px solid black; padding: 2px;">Electrical Data</div> <p data-bbox="129 663 1133 1032">Impedance 50Ω Frequency Range DC to 34.5GHz VSWR ≤ 1.2 (DC To 34.5GHz) Insertion Loss ≤ 0.05 x √f(GHz) dB Insulation Resistance ≥ 5000MΩ Dielectric Withstanding Voltage (at sea level) 1000 V rms Working Voltage (at sea level) 335 V rms RF Leakage ≥ 100dB to 1GHz</p>	
<div data-bbox="129 1155 531 1205" style="border: 1px solid black; padding: 2px;">Mechanical Data</div> <p data-bbox="129 1211 1018 1391">Recommended Coupling Nut Torque 7.1 to 9.7 in-lbs Coupling Proof Torque 15 in-lbs Contact Captivation-axial ≥ 6.1 lbs Durability (mating) ≥ 500</p>	
<div data-bbox="129 1559 531 1608" style="border: 1px solid black; padding: 2px;">Environmental Data</div> <p data-bbox="129 1615 1362 1839">Temperature Range -40°C to +165°C Thermal Shock MIL-STD-202, Method 107, Condition B Moisture Resistance MIL-STD-202, Method 206 Corrosion MIL-STD-202, Method 101, Condition B RoHS Compliant</p>	

ADS-VNAPC8PC3

