

ADS-VNAPC8-2.4/8

3.5mm NMD jack to 2.4mm jack  
34.5GHz VSWR 1.2

50Ω

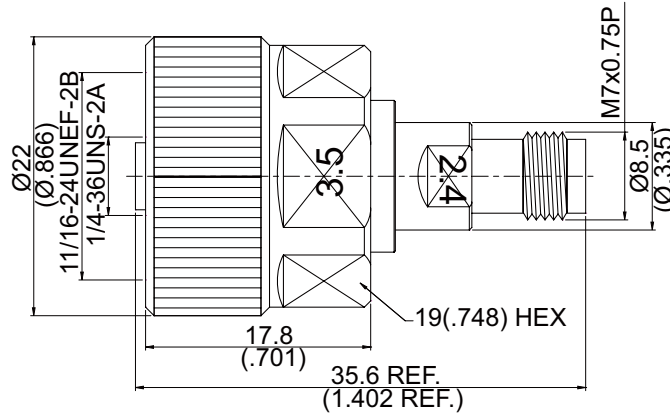

Note:Ruggedized 3.5 jack to be mounted directly on vector network analyzer.

Parts	Material	Plating (Micro-inch)
Contact Pin	Beryllium Copper	Gold 4 Over Nickel-Phosphorus Alloy 80 Over Copper 20
Insulator	PSU	
Insulator	PEI	
Body	Stainless Steel	Passivated
Coupling Nut	Stainless Steel	Passivated

Weight:

This part number complies with RoHS.

Notice: JYEBAO reserves the right to make modifications deemed appropriate.

ADS-VNAPC8-2.4/8	3.5mm NMD jack to 2.4mm jack 34.5GHz VSWR 1.2																	
<div style="border: 1px solid black; padding: 2px; margin-bottom: 5px;">Interface</div> Standard Mechanically compatible with	<table border="1" style="width: 100%; border-collapse: collapse;"> <thead> <tr> <th style="width: 50%;"></th> <th style="width: 25%;">2.4</th> <th style="width: 25%;">3.5</th> </tr> </thead> <tbody> <tr> <td>Standard</td> <td>MIL-STD-348B</td> <td>IEC60169-23</td> </tr> <tr> <td>Mechanically compatible with</td> <td>1.85</td> <td>SMA &amp; 2.92</td> </tr> </tbody> </table>		2.4	3.5	Standard	MIL-STD-348B	IEC60169-23	Mechanically compatible with	1.85	SMA & 2.92								
	2.4	3.5																
Standard	MIL-STD-348B	IEC60169-23																
Mechanically compatible with	1.85	SMA & 2.92																
<div style="border: 1px solid black; padding: 2px; margin-bottom: 5px;">Electrical Data</div> Impedance Frequency Range VSWR Insertion Loss Insulation Resistance Dielectric Withstanding Voltage (at sea level) Working Voltage (at sea level) RF leakage	<table style="width: 100%;"> <tbody> <tr> <td>Impedance</td> <td>50Ω</td> </tr> <tr> <td>Frequency Range</td> <td>DC To 34.5GHz</td> </tr> <tr> <td>VSWR</td> <td>≤ 1.2 (DC To 34.5GHz)</td> </tr> <tr> <td>Insertion Loss</td> <td>≤ 0.06 x √f(GHz) dB</td> </tr> <tr> <td>Insulation Resistance</td> <td>≥ 5000MΩ</td> </tr> <tr> <td>Dielectric Withstanding Voltage (at sea level)</td> <td>500 V rms</td> </tr> <tr> <td>Working Voltage (at sea level)</td> <td>150 V rms</td> </tr> <tr> <td>RF leakage</td> <td>≥ 100dB to 1GHz</td> </tr> </tbody> </table>		Impedance	50Ω	Frequency Range	DC To 34.5GHz	VSWR	≤ 1.2 (DC To 34.5GHz)	Insertion Loss	≤ 0.06 x √f(GHz) dB	Insulation Resistance	≥ 5000MΩ	Dielectric Withstanding Voltage (at sea level)	500 V rms	Working Voltage (at sea level)	150 V rms	RF leakage	≥ 100dB to 1GHz
Impedance	50Ω																	
Frequency Range	DC To 34.5GHz																	
VSWR	≤ 1.2 (DC To 34.5GHz)																	
Insertion Loss	≤ 0.06 x √f(GHz) dB																	
Insulation Resistance	≥ 5000MΩ																	
Dielectric Withstanding Voltage (at sea level)	500 V rms																	
Working Voltage (at sea level)	150 V rms																	
RF leakage	≥ 100dB to 1GHz																	
<div style="border: 1px solid black; padding: 2px; margin-bottom: 5px;">Mechanical Data</div> Recommended Coupling Nut Torque Coupling Proof Torque Contact Captivation-axial Durability (mating)	<table border="1" style="width: 100%; border-collapse: collapse;"> <thead> <tr> <th style="width: 50%;"></th> <th style="width: 25%;">2.4</th> <th style="width: 25%;">3.5</th> </tr> </thead> <tbody> <tr> <td>Recommended Coupling Nut Torque</td> <td>7.08 to 9.74 in-lbs</td> <td>7.1 to 9.7 in-lbs</td> </tr> <tr> <td>Coupling Proof Torque</td> <td>15 in-lbs</td> <td>15 in-lbs</td> </tr> <tr> <td>Contact Captivation-axial</td> <td>≥ 4.5 lbs</td> <td>≥ 6.1 lbs</td> </tr> <tr> <td>Durability (mating)</td> <td>≥ 500</td> <td>≥ 500</td> </tr> </tbody> </table>			2.4	3.5	Recommended Coupling Nut Torque	7.08 to 9.74 in-lbs	7.1 to 9.7 in-lbs	Coupling Proof Torque	15 in-lbs	15 in-lbs	Contact Captivation-axial	≥ 4.5 lbs	≥ 6.1 lbs	Durability (mating)	≥ 500	≥ 500	
	2.4	3.5																
Recommended Coupling Nut Torque	7.08 to 9.74 in-lbs	7.1 to 9.7 in-lbs																
Coupling Proof Torque	15 in-lbs	15 in-lbs																
Contact Captivation-axial	≥ 4.5 lbs	≥ 6.1 lbs																
Durability (mating)	≥ 500	≥ 500																
<div style="border: 1px solid black; padding: 2px; margin-bottom: 5px;">Environmental Data</div> Temperature Range Thermal Shock Moisture Resistance Corrosion RoHS	<table style="width: 100%;"> <tbody> <tr> <td>Temperature Range</td> <td>-40°C to +140°C</td> </tr> <tr> <td>Thermal Shock</td> <td>MIL-STD-202, Method 107, Condition B</td> </tr> <tr> <td>Moisture Resistance</td> <td>MIL-STD-202, Method 206</td> </tr> <tr> <td>Corrosion</td> <td>MIL-STD-202, Method 101, Condition B</td> </tr> <tr> <td>RoHS</td> <td>Compliant</td> </tr> </tbody> </table>		Temperature Range	-40°C to +140°C	Thermal Shock	MIL-STD-202, Method 107, Condition B	Moisture Resistance	MIL-STD-202, Method 206	Corrosion	MIL-STD-202, Method 101, Condition B	RoHS	Compliant						
Temperature Range	-40°C to +140°C																	
Thermal Shock	MIL-STD-202, Method 107, Condition B																	
Moisture Resistance	MIL-STD-202, Method 206																	
Corrosion	MIL-STD-202, Method 101, Condition B																	
RoHS	Compliant																	

# ADS-VNAPC8-2.4/8

