

ADS-VNAPC3PC8

3.5mm NMD Plug To 3.5mm Jack
34.5GHz VSWR 1.2

50Ω

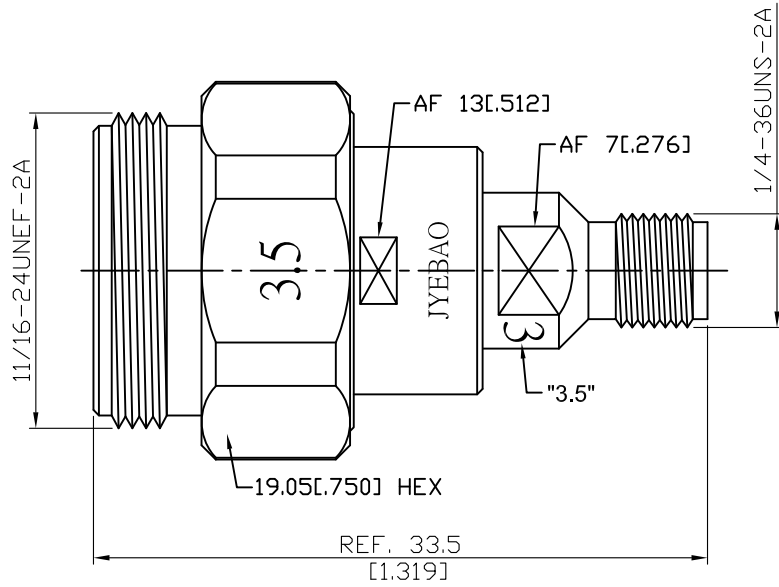

Parts	Material	Plating (Micro-inch)
Retainer Ring	Brass	Tin-Zinc-Copper-Alloy 100 Over Copper 50
Contact Pin	Beryllium Copper	Gold 4 Over Nickel-Phosphorus Alloy 80 Over Copper 20
Insulator	PEI	
Body	Stainless Steel	Passivated
Coupling Nut	Stainless Steel	Passivated

This part number complies with RoHS.

Notice: JYEBAO reserves the right to make modifications deemed appropriate.

ADS-VNAPC3PC8	3.5mm NMD Plug To 3.5mm Jack 34.5GHz VSWR 1.2																		
<table border="0"> <tr> <td colspan="2" data-bbox="129 342 531 392">Interface</td> </tr> <tr> <td data-bbox="129 398 794 436">Standard</td> <td data-bbox="794 398 1482 436">IEC60169-23</td> </tr> <tr> <td data-bbox="129 443 794 481">Mechanically compatible with</td> <td data-bbox="794 443 1482 481">2.92 & SMA</td> </tr> </table>		Interface		Standard	IEC60169-23	Mechanically compatible with	2.92 & SMA												
Interface																			
Standard	IEC60169-23																		
Mechanically compatible with	2.92 & SMA																		
<table border="0"> <tr> <td colspan="2" data-bbox="129 602 531 651">Electrical Data</td> </tr> <tr> <td data-bbox="129 658 794 696">Impedance</td> <td data-bbox="794 658 1482 696">50Ω</td> </tr> <tr> <td data-bbox="129 703 794 741">Frequency Range</td> <td data-bbox="794 703 1482 741">DC to 34.5GHz</td> </tr> <tr> <td data-bbox="129 748 794 786">VSWR</td> <td data-bbox="794 748 1482 786">≤ 1.2 (DC To 34.5GHz)</td> </tr> <tr> <td data-bbox="129 792 794 831">Insertion Loss</td> <td data-bbox="794 792 1482 831">≤ 0.05 x √f(GHz) dB</td> </tr> <tr> <td data-bbox="129 837 794 875">Insulation Resistance</td> <td data-bbox="794 837 1482 875">≥ 5000MΩ</td> </tr> <tr> <td data-bbox="129 882 794 920">Dielectric Withstanding Voltage (at sea level)</td> <td data-bbox="794 882 1482 920">1000 V rms</td> </tr> <tr> <td data-bbox="129 927 794 965">Working Voltage (at sea level)</td> <td data-bbox="794 927 1482 965">335 V rms</td> </tr> <tr> <td data-bbox="129 972 794 1010">RF Leakage</td> <td data-bbox="794 972 1482 1010">≥ 100dB to 1GHz</td> </tr> </table>		Electrical Data		Impedance	50Ω	Frequency Range	DC to 34.5GHz	VSWR	≤ 1.2 (DC To 34.5GHz)	Insertion Loss	≤ 0.05 x √f(GHz) dB	Insulation Resistance	≥ 5000MΩ	Dielectric Withstanding Voltage (at sea level)	1000 V rms	Working Voltage (at sea level)	335 V rms	RF Leakage	≥ 100dB to 1GHz
Electrical Data																			
Impedance	50Ω																		
Frequency Range	DC to 34.5GHz																		
VSWR	≤ 1.2 (DC To 34.5GHz)																		
Insertion Loss	≤ 0.05 x √f(GHz) dB																		
Insulation Resistance	≥ 5000MΩ																		
Dielectric Withstanding Voltage (at sea level)	1000 V rms																		
Working Voltage (at sea level)	335 V rms																		
RF Leakage	≥ 100dB to 1GHz																		
<table border="0"> <tr> <td colspan="2" data-bbox="129 1149 531 1198">Mechanical Data</td> </tr> <tr> <td data-bbox="129 1205 794 1243">Recommended Coupling Nut Torque</td> <td data-bbox="794 1205 1482 1243">7.1 to 9.7 in-lbs</td> </tr> <tr> <td data-bbox="129 1249 794 1288">Coupling Proof Torque</td> <td data-bbox="794 1249 1482 1288">15 in-lbs</td> </tr> <tr> <td data-bbox="129 1294 794 1332">Contact Captivation-axial</td> <td data-bbox="794 1294 1482 1332">≥ 6.1 lbs</td> </tr> <tr> <td data-bbox="129 1339 794 1377">Durability (mating)</td> <td data-bbox="794 1339 1482 1377">≥ 500</td> </tr> </table>		Mechanical Data		Recommended Coupling Nut Torque	7.1 to 9.7 in-lbs	Coupling Proof Torque	15 in-lbs	Contact Captivation-axial	≥ 6.1 lbs	Durability (mating)	≥ 500								
Mechanical Data																			
Recommended Coupling Nut Torque	7.1 to 9.7 in-lbs																		
Coupling Proof Torque	15 in-lbs																		
Contact Captivation-axial	≥ 6.1 lbs																		
Durability (mating)	≥ 500																		
<table border="0"> <tr> <td colspan="2" data-bbox="129 1552 531 1601">Environmental Data</td> </tr> <tr> <td data-bbox="129 1608 794 1646">Temperature Range</td> <td data-bbox="794 1608 1482 1646">-40°C to +165°C</td> </tr> <tr> <td data-bbox="129 1653 794 1691">Thermal Shock</td> <td data-bbox="794 1653 1482 1691">MIL-STD-202, Method 107, Condition B</td> </tr> <tr> <td data-bbox="129 1697 794 1736">Moisture Resistance</td> <td data-bbox="794 1697 1482 1736">MIL-STD-202, Method 206</td> </tr> <tr> <td data-bbox="129 1742 794 1780">Corrosion</td> <td data-bbox="794 1742 1482 1780">MIL-STD-202, Method 101, Condition B</td> </tr> <tr> <td data-bbox="129 1787 794 1825">RoHS</td> <td data-bbox="794 1787 1482 1825">Compliant</td> </tr> </table>		Environmental Data		Temperature Range	-40°C to +165°C	Thermal Shock	MIL-STD-202, Method 107, Condition B	Moisture Resistance	MIL-STD-202, Method 206	Corrosion	MIL-STD-202, Method 101, Condition B	RoHS	Compliant						
Environmental Data																			
Temperature Range	-40°C to +165°C																		
Thermal Shock	MIL-STD-202, Method 107, Condition B																		
Moisture Resistance	MIL-STD-202, Method 206																		
Corrosion	MIL-STD-202, Method 101, Condition B																		
RoHS	Compliant																		

ADS-VNAPC3PC8

