

ADS-N3T8-18-1.15

Stainless N Plug To TNC Jack
18GHz VSWR 1.15

50Ω

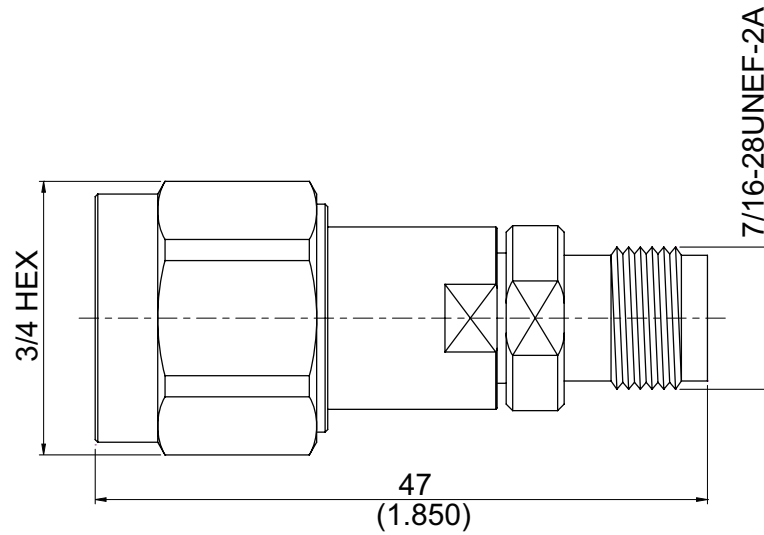

Parts	Material	Plating (Micro-inch)
Retainer Ring	Brass	Tin-Zinc-Copper-Alloy 100 Over Copper 50
Gasket	Silicon	
Insulator	Teflon	
Contact Pin	Beryllium Copper	Gold 4 Over Nickel-Phosphorus Alloy 80 Over Copper 20
Body	Stainless Steel	Passivated
Coupling Nut	Stainless Steel	Passivated

Weight:

This part number complies with RoHS.

Notice: JYEBAO reserves the right to make modifications deemed appropriate.

ADS-N3T8-18-1.15	Stainless N Plug To TNC Jack 18GHz VSWR 1.15	
<div style="border: 1px solid black; padding: 2px; margin-bottom: 5px;">Interface</div> Standard	N MIL-STD-348B	TNC MIL-STD-348B
<div style="border: 1px solid black; padding: 2px; margin-bottom: 5px;">Electrical Data</div> Impedance Frequency Range VSWR Insertion Loss Insulation Resistance Dielectric Withstanding Voltage (at sea level) Working Voltage (at sea level)	50Ω DC To 18GHz ≤ 1.15 (DC To 18GHz) ≤ 0.05 x √f(GHz) dB ≥ 5000MΩ 1500 V rms 500 V rms	
<div style="border: 1px solid black; padding: 2px; margin-bottom: 5px;">Mechanical Data</div> Recommended Coupling Nut Torque Coupling Proof Torque Coupling Nut Retention Force Contact Captivation-axial Durability (mating)	N 6 to 10 in-lbs 15 in-lbs ≥ 101.2 lbs ≥ 6.3 lbs ≥ 500	TNC 4.1 to 6.1 in-lbs 15 in-lbs NA ≥ 6.1 lbs ≥ 500
<div style="border: 1px solid black; padding: 2px; margin-bottom: 5px;">Environmental Data</div> Temperature Range Thermal Shock Moisture Resistance Corrosion RoHS	-65°C to +165°C MIL-STD-202, Method 107, Condition B MIL-STD-202, Method 206 MIL-STD-202, Method 101, Condition B Compliant	

ADS-N3T8-18-1.15

