

ADS-K8N8-BF-18B

K Jack To N Jack Bulkhead
18GHz VSWR 1.2

50Ω

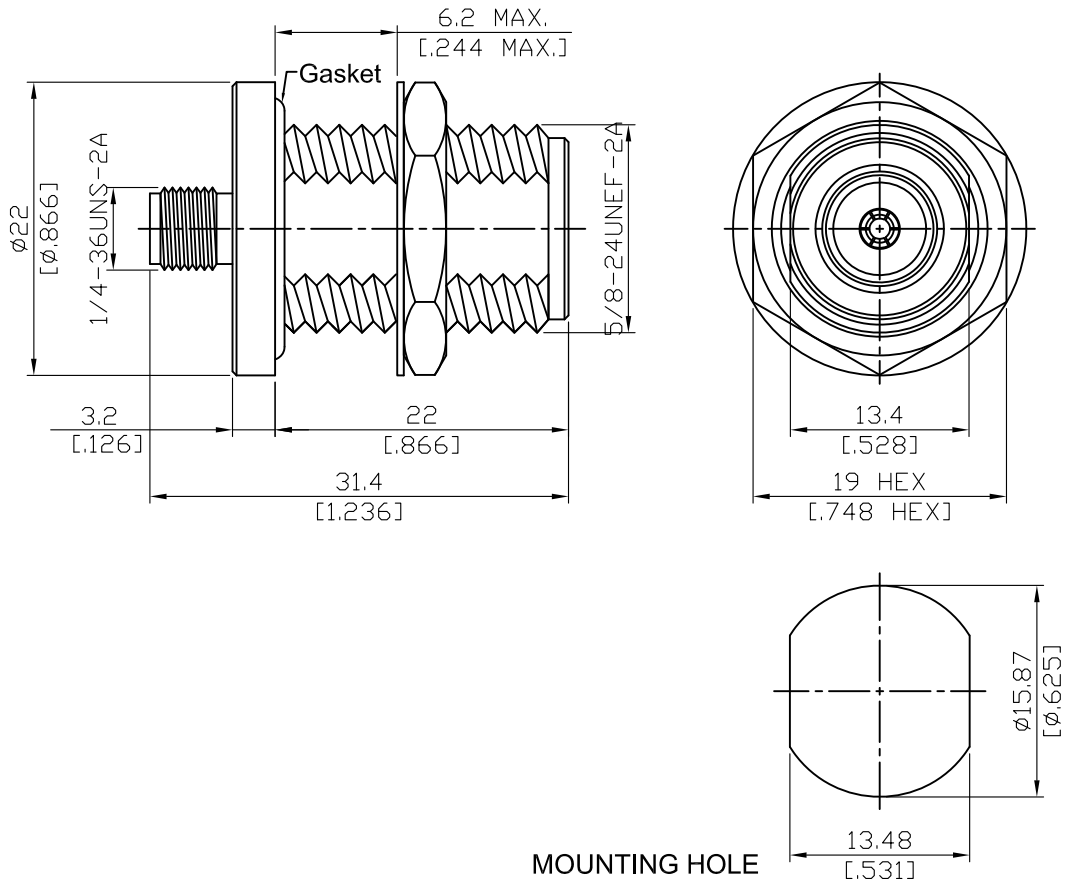

Parts	Material	Plating (Micro-inch)
Hex Nut	Stainless Steel	Passivated
Lock Washer	Stainless Steel	Passivated
Gasket	Silicone	
Contact Pin	Beryllium Copper	Gold 4 Over Nickel-Phosphorus Alloy 80 Over Copper 20
Holder	Brass	Gold 4 Over Nickel-Phosphorus Alloy 80 Over Copper 20
Insulator	Teflon	
Body	Stainless Steel	Passivated

This part number complies with RoHS.

Notice: JYEBAO reserves the right to make modifications deemed appropriate.

ADS-K8N8-BF-18B	K Jack To N Jack Bulkhead 18GHz VSWR 1.2	
<div style="border: 1px solid black; padding: 2px; margin-bottom: 5px;">Interface</div> Standard Mechanically compatible with	2.92 <hr/> MIL-STD-348B <hr/> 3.5 & SMA	N <hr/> MIL-STD-348B <hr/>
<div style="border: 1px solid black; padding: 2px; margin-bottom: 5px;">Electrical Data</div> Impedance Frequency Range VSWR Insertion Loss Insulation Resistance Dielectric Withstanding Voltage (at sea level) Working Voltage (at sea level)	50Ω DC To 18GHz ≤ 1.2 (DC To 18GHz) $\leq 0.03 \times \sqrt{f(\text{GHz})}$ dB $\geq 5000\text{M}\Omega$ 750 V rms 250 V rms	
<div style="border: 1px solid black; padding: 2px; margin-bottom: 5px;">Mechanical Data</div> Recommended Coupling Nut Torque Coupling Proof Torque Contact Captivation-axial Durability (mating)	2.92 <hr/> 11.47 in-lbs <hr/> 15 in-lbs <hr/> ≥ 4.9 lbs <hr/> ≥ 500	N <hr/> 6 to 10 in-lbs <hr/> 15 in-lbs <hr/> ≥ 6.3 lbs <hr/> ≥ 500
<div style="border: 1px solid black; padding: 2px; margin-bottom: 5px;">Environmental Data</div> Temperature Range Thermal Shock Moisture Resistance Corrosion RoHS	-65°C to +165°C MIL-STD-202, Method 107, Condition B MIL-STD-202, Method 206 MIL-STD-202, Method 101, Condition B Compliant	

ADS-K8N8-BF-18B

