

ADS-A8T8-P4B-1.15	SMA Jack to TNC Jack With 17.5mm SQ 4 Hole Flange; 18GHz VSWR 1.15	50Ω
-------------------	---	-----

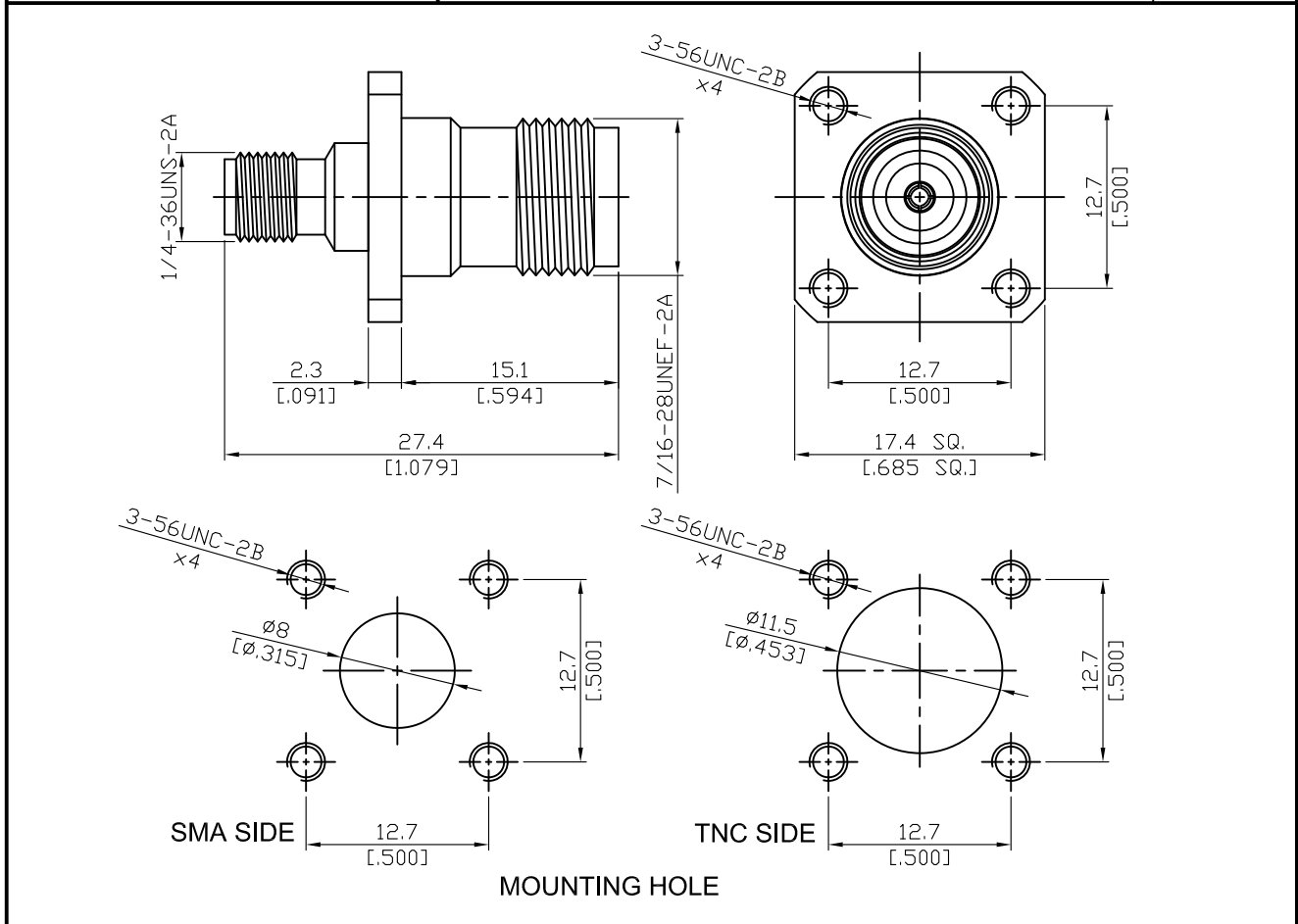

Parts	Material	Plating (Micro-inch)
Contact Pin	Beryllium Copper	Gold 4 Over Nickel-Phosphorus Alloy 80 Over Copper 20
Insulator	Teflon	
Body	Stainless Steel	Passivated

--	--

This part number complies with RoHS.

Notice: JYEBAO reserves the right to make modifications deemed appropriate.

ADS-A8T8-P4B-1.15		SMA Jack to TNC Jack With 17.5mm SQ 4 Hole Flange;18GHz VSWR 1.15	
Interface		SMA	TNC
Standard		MIL-STD-348B	MIL-STD-348B
Mechanically compatible with		2.92 & 3.5	
Electrical Data			
Impedance		50Ω	
Frequency Range		DC To 18GHz	
VSWR		≤ 1.15 (DC To 18GHz)	
Insertion Loss		≤ 0.05 x √f(GHz) dB	
Insulation Resistance		≥ 5000MΩ	
Dielectric Withstanding Voltage (at sea level)		1500 V rms	
Working Voltage (at sea level)		500 V rms	
Mechanical Data		SMA	TNC
Recommended Coupling Nut Torque		7 to 9.5 in-lbs	4.1 to 6.1 in-lbs
Coupling Proof Torque		15 in-lbs	15 in-lbs
Contact Captivation-axial		≥ 6.1 lbs	≥ 6.1 lbs
Durability (mating)		≥ 500	≥ 500
Environmental Data			
Temperature Range		-65°C to +165°C	
Thermal Shock		MIL-STD-202, Method	
Moisture Resistance		MIL-STD-202, Method	
Corrosion		MIL-STD-202, Method	
RoHS		Compliant	

Notice: JYEBAO reserves the right to make modifications deemed appropriate.

ADS-A8T8-P4B-1.15

