

ADS-A8T8-P4A-1.2

SMA jack to TNC jack with 4-hole flange  
18GHz VSWR 1.2

50Ω

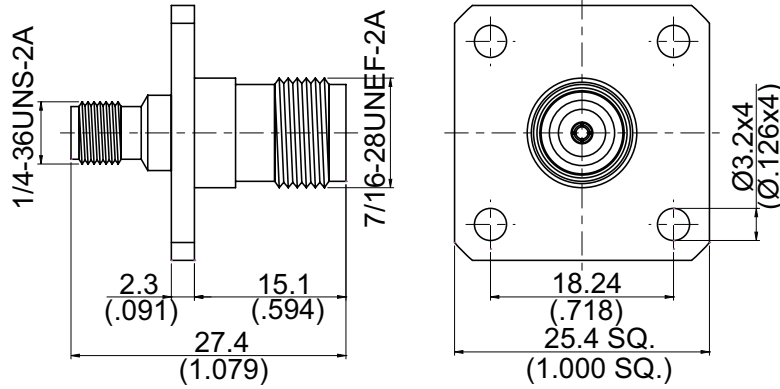

MOUNTING HOLE

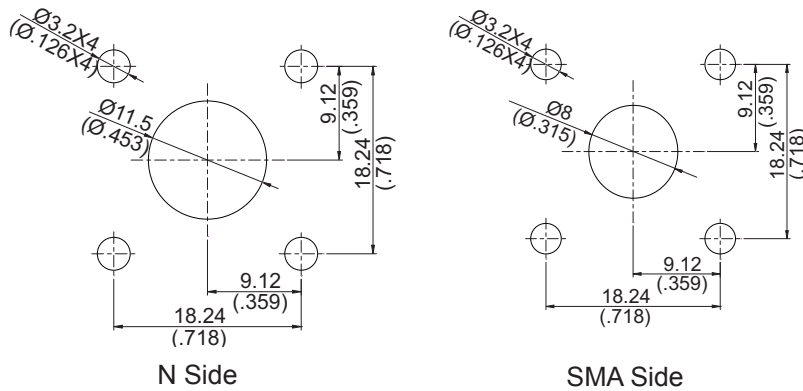

N Side

SMA Side

Parts	Material	Plating (Micro-inch)
Contact Pin	Beryllium Copper	Gold 4 Over Nickel-Phosphorus Alloy 80 Over Copper 20
Insulator	Teflon	
Body	Stainless Steel	Passivated

Weight:

This part number complies with RoHS.

Notice: JYEBAO reserves the right to make modifications deemed appropriate.

ADS-A8T8-P4A-1.2	SMA jack to TNC jack with 4-hole flange 18GHz VSWR 1.2													
<div style="border: 1px solid black; padding: 2px; margin-bottom: 5px;">Interface</div> Standard Mechanically compatible with	<table border="1" style="width: 100%; border-collapse: collapse;"> <thead> <tr> <th style="width: 50%;">SMA</th> <th style="width: 50%;">TNC</th> </tr> </thead> <tbody> <tr> <td>MIL-STD-348B</td> <td>MIL-STD-348B</td> </tr> <tr> <td>2.92 &amp; 3.5</td> <td></td> </tr> </tbody> </table>	SMA	TNC	MIL-STD-348B	MIL-STD-348B	2.92 & 3.5								
SMA	TNC													
MIL-STD-348B	MIL-STD-348B													
2.92 & 3.5														
<div style="border: 1px solid black; padding: 2px; margin-bottom: 5px;">Electrical Data</div> Impedance Frequency Range VSWR Insertion Loss Insulation Resistance Dielectric Withstanding Voltage (at sea level) Working Voltage (at sea level)	<table style="width: 100%;"> <tbody> <tr> <td style="width: 50%;">50Ω</td> <td style="width: 50%;">DC To 18GHz</td> </tr> <tr> <td>≤ 1.2 (DC To 18GHz)</td> <td></td> </tr> <tr> <td>≤ 0.05 x √f(GHz) dB</td> <td></td> </tr> <tr> <td>≥ 5000MΩ</td> <td></td> </tr> <tr> <td>1500 V rms</td> <td></td> </tr> <tr> <td>500 V rms</td> <td></td> </tr> </tbody> </table>		50Ω	DC To 18GHz	≤ 1.2 (DC To 18GHz)		≤ 0.05 x √f(GHz) dB		≥ 5000MΩ		1500 V rms		500 V rms	
50Ω	DC To 18GHz													
≤ 1.2 (DC To 18GHz)														
≤ 0.05 x √f(GHz) dB														
≥ 5000MΩ														
1500 V rms														
500 V rms														
<div style="border: 1px solid black; padding: 2px; margin-bottom: 5px;">Mechanical Data</div> Recommended Coupling Nut Torque Coupling Proof Torque Contact Captivation-axial Durability (mating)	<table border="1" style="width: 100%; border-collapse: collapse;"> <thead> <tr> <th style="width: 50%;">SMA</th> <th style="width: 50%;">TNC</th> </tr> </thead> <tbody> <tr> <td>7 to 9.5 in-lbs</td> <td>4.1 to 6.1 in-lbs</td> </tr> <tr> <td>15 in-lbs</td> <td>15 in-lbs</td> </tr> <tr> <td>≥ 6.1 lbs</td> <td>≥ 6.1 lbs</td> </tr> <tr> <td>≥ 500</td> <td>≥ 500</td> </tr> </tbody> </table>	SMA	TNC	7 to 9.5 in-lbs	4.1 to 6.1 in-lbs	15 in-lbs	15 in-lbs	≥ 6.1 lbs	≥ 6.1 lbs	≥ 500	≥ 500			
SMA	TNC													
7 to 9.5 in-lbs	4.1 to 6.1 in-lbs													
15 in-lbs	15 in-lbs													
≥ 6.1 lbs	≥ 6.1 lbs													
≥ 500	≥ 500													
<div style="border: 1px solid black; padding: 2px; margin-bottom: 5px;">Environmental Data</div> Temperature Range Thermal Shock Moisture Resistance Corrosion RoHS	<table style="width: 100%;"> <tbody> <tr> <td style="width: 50%;">-65°C to +165°C</td> <td style="width: 50%;">MIL-STD-202, Method</td> </tr> <tr> <td></td> <td>MIL-STD-202, Method</td> </tr> <tr> <td></td> <td>MIL-STD-202, Method</td> </tr> <tr> <td></td> <td>Compliant</td> </tr> </tbody> </table>		-65°C to +165°C	MIL-STD-202, Method		MIL-STD-202, Method		MIL-STD-202, Method		Compliant				
-65°C to +165°C	MIL-STD-202, Method													
	MIL-STD-202, Method													
	MIL-STD-202, Method													
	Compliant													

Notice: JYEBAO reserves the right to make modifications deemed appropriate.

# ADS-A8T8-P4A-1.2

