

ADS-A8N8-P4-18-1.15

SMA Jack To N Jack 4 Hole Flange  
IP67 Mated, 18GHz VSWR 1.15

50Ω

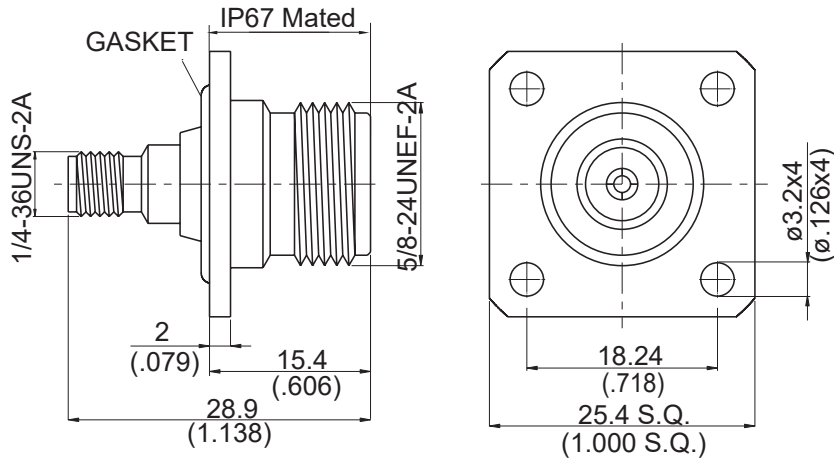

MOUNTING HOLE

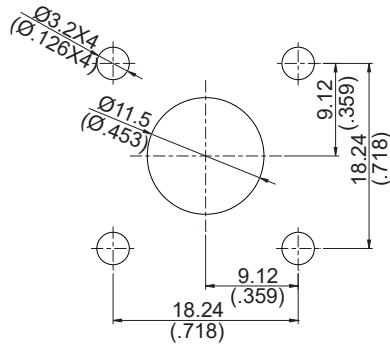

Parts	Material	Plating (Micro-inch)
Gasket	Silicone	
Contact Pin	Beryllium Copper	Gold 4 Over Nickel-Phosphorus Alloy 80 Over Copper 20
Insulator	Teflon	
Body	Stainless Steel	Passivated

Weight: 26.44 g

This part number complies with RoHS.

Notice: JYEBAO reserves the right to make modifications deemed appropriate.

ADS-A8N8-P4-18-1.15	SMA Jack To N Jack 4 Hole Flange IP67 Mated, 18GHz VSWR 1.15																
<div style="border: 1px solid black; padding: 2px; margin-bottom: 5px;">Interface</div> Standard Mechanically compatible with	<table border="1" style="width: 100%; border-collapse: collapse;"> <thead> <tr> <th style="width: 50%;">SMA</th> <th style="width: 50%;">N</th> </tr> </thead> <tbody> <tr> <td style="text-align: center;">MIL-STD-348B</td> <td style="text-align: center;">MIL-STD-348B</td> </tr> <tr> <td style="text-align: center;">2.92 &amp; 3.5</td> <td></td> </tr> </tbody> </table>	SMA	N	MIL-STD-348B	MIL-STD-348B	2.92 & 3.5											
SMA	N																
MIL-STD-348B	MIL-STD-348B																
2.92 & 3.5																	
<div style="border: 1px solid black; padding: 2px; margin-bottom: 5px;">Electrical Data</div> Impedance Frequency Range VSWR Insertion Loss Insulation Resistance Dielectric Withstanding Voltage (at sea level) Working Voltage (at sea level)	<table style="width: 100%; border-collapse: collapse;"> <tbody> <tr> <td style="width: 50%;"></td> <td style="width: 50%; text-align: center;">50Ω</td> </tr> <tr> <td></td> <td style="text-align: center;">DC To 18GHz</td> </tr> <tr> <td></td> <td style="text-align: center;">≤ 1.15 (DC To 18GHz)</td> </tr> <tr> <td></td> <td style="text-align: center;">≤ 0.04 x √f(GHz) dB</td> </tr> <tr> <td></td> <td style="text-align: center;">≥ 5000MΩ</td> </tr> <tr> <td></td> <td style="text-align: center;">1500 V rms</td> </tr> <tr> <td></td> <td style="text-align: center;">500 V rms</td> </tr> </tbody> </table>			50Ω		DC To 18GHz		≤ 1.15 (DC To 18GHz)		≤ 0.04 x √f(GHz) dB		≥ 5000MΩ		1500 V rms		500 V rms	
	50Ω																
	DC To 18GHz																
	≤ 1.15 (DC To 18GHz)																
	≤ 0.04 x √f(GHz) dB																
	≥ 5000MΩ																
	1500 V rms																
	500 V rms																
<div style="border: 1px solid black; padding: 2px; margin-bottom: 5px;">Mechanical Data</div> Recommended Coupling Nut Torque Coupling Proof Torque Contact Captivation-axial Durability (mating)	<table border="1" style="width: 100%; border-collapse: collapse;"> <thead> <tr> <th style="width: 50%;"></th> <th style="width: 25%; text-align: center;">SMA</th> <th style="width: 25%; text-align: center;">N</th> </tr> </thead> <tbody> <tr> <td style="width: 50%;"></td> <td style="text-align: center;">7 to 9.5 in-lbs</td> <td style="text-align: center;">6 to 10 in-lbs</td> </tr> <tr> <td></td> <td style="text-align: center;">15 in-lbs</td> <td style="text-align: center;">15 in-lbs</td> </tr> <tr> <td></td> <td style="text-align: center;">≥ 6.1 lbs</td> <td style="text-align: center;">≥ 6.3 lbs</td> </tr> <tr> <td></td> <td style="text-align: center;">≥ 500</td> <td style="text-align: center;">≥ 500</td> </tr> </tbody> </table>			SMA	N		7 to 9.5 in-lbs	6 to 10 in-lbs		15 in-lbs	15 in-lbs		≥ 6.1 lbs	≥ 6.3 lbs		≥ 500	≥ 500
	SMA	N															
	7 to 9.5 in-lbs	6 to 10 in-lbs															
	15 in-lbs	15 in-lbs															
	≥ 6.1 lbs	≥ 6.3 lbs															
	≥ 500	≥ 500															
<div style="border: 1px solid black; padding: 2px; margin-bottom: 5px;">Environmental Data</div> Temperature Range Thermal Shock Moisture Resistance Corrosion RoHS	<table style="width: 100%; border-collapse: collapse;"> <tbody> <tr> <td style="width: 50%;"></td> <td style="width: 50%; text-align: center;">-65°C to +165°C</td> </tr> <tr> <td></td> <td style="text-align: center;">MIL-STD-202, Method 107, Condition B</td> </tr> <tr> <td></td> <td style="text-align: center;">MIL-STD-202, Method 206</td> </tr> <tr> <td></td> <td style="text-align: center;">MIL-STD-202, Method 101, Condition B</td> </tr> <tr> <td></td> <td style="text-align: center;">Compliant</td> </tr> </tbody> </table>			-65°C to +165°C		MIL-STD-202, Method 107, Condition B		MIL-STD-202, Method 206		MIL-STD-202, Method 101, Condition B		Compliant					
	-65°C to +165°C																
	MIL-STD-202, Method 107, Condition B																
	MIL-STD-202, Method 206																
	MIL-STD-202, Method 101, Condition B																
	Compliant																

Notice: JYEBAO reserves the right to make modifications deemed appropriate.

# ADS-A8N8-P4-18-1.15

