

ADS-A8N8-18A-1.15	Stainless Precision SMA Jack To N Jack 18GHz VSWR 1.15	50Ω
-------------------	---	------------

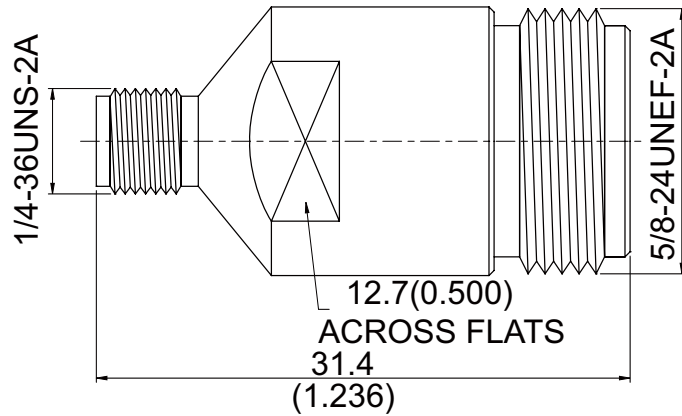

Parts	Material	Plating (Micro-inch)
Contact Pin	Beryllium Copper	Gold 4 Over Nickel-Phosphorus Alloy 80 Over Copper 20
Insulator	Teflon	
Body	Stainless	Passivated

Weight: 19 g

This part number complies with RoHS.

Notice: JYBAO reserves the right to make modifications deemed appropriate.

ADS-A8N8-18A-1.15	Stainless Precision SMA Jack To N Jack 18GHz VSWR 1.15																	
<div style="border: 1px solid black; padding: 2px; margin-bottom: 5px;">Interface</div> Standard Mechanically compatible with	<table border="1" style="width: 100%; border-collapse: collapse;"> <thead> <tr> <th style="width: 50%;">SMA</th> <th style="width: 50%;">N</th> </tr> </thead> <tbody> <tr> <td>MIL-STD-348B</td> <td>MIL-STD-348B</td> </tr> <tr> <td>2.92 & 3.5</td> <td></td> </tr> </tbody> </table>	SMA	N	MIL-STD-348B	MIL-STD-348B	2.92 & 3.5												
SMA	N																	
MIL-STD-348B	MIL-STD-348B																	
2.92 & 3.5																		
<div style="border: 1px solid black; padding: 2px; margin-bottom: 5px;">Electrical Data</div> Impedance Frequency Range VSWR Insertion Loss Insulation Resistance Dielectric Withstanding Voltage (at sea level) Working Voltage (at sea level)	<table style="width: 100%;"> <tbody> <tr> <td style="width: 50%;">Impedance</td> <td style="width: 50%;">50Ω</td> </tr> <tr> <td>Frequency Range</td> <td>DC To 18GHz</td> </tr> <tr> <td>VSWR</td> <td>≤ 1.15 (DC To 18GHz)</td> </tr> <tr> <td>Insertion Loss</td> <td>≤ 0.04 x √f(GHz) dB</td> </tr> <tr> <td>Insulation Resistance</td> <td>≥ 5000MΩ</td> </tr> <tr> <td>Dielectric Withstanding Voltage (at sea level)</td> <td>1500 V rms</td> </tr> <tr> <td>Working Voltage (at sea level)</td> <td>500 V rms</td> </tr> </tbody> </table>		Impedance	50Ω	Frequency Range	DC To 18GHz	VSWR	≤ 1.15 (DC To 18GHz)	Insertion Loss	≤ 0.04 x √f(GHz) dB	Insulation Resistance	≥ 5000MΩ	Dielectric Withstanding Voltage (at sea level)	1500 V rms	Working Voltage (at sea level)	500 V rms		
Impedance	50Ω																	
Frequency Range	DC To 18GHz																	
VSWR	≤ 1.15 (DC To 18GHz)																	
Insertion Loss	≤ 0.04 x √f(GHz) dB																	
Insulation Resistance	≥ 5000MΩ																	
Dielectric Withstanding Voltage (at sea level)	1500 V rms																	
Working Voltage (at sea level)	500 V rms																	
<div style="border: 1px solid black; padding: 2px; margin-bottom: 5px;">Mechanical Data</div> Recommended Coupling Nut Torque Coupling Proof Torque Contact Captivation-axial Durability (mating)	<table border="1" style="width: 100%; border-collapse: collapse;"> <thead> <tr> <th style="width: 50%;">SMA</th> <th style="width: 50%;">N</th> </tr> </thead> <tbody> <tr> <td>Recommended Coupling Nut Torque</td> <td>7 to 9.5 in-lbs</td> </tr> <tr> <td>Coupling Proof Torque</td> <td>6 to 10 in-lbs</td> </tr> <tr> <td>Contact Captivation-axial</td> <td>15 in-lbs</td> </tr> <tr> <td>Durability (mating)</td> <td>≥ 6.1 lbs</td> </tr> <tr> <td></td> <td>≥ 6.3 lbs</td> </tr> <tr> <td></td> <td>≥ 500</td> </tr> <tr> <td></td> <td>≥ 500</td> </tr> </tbody> </table>		SMA	N	Recommended Coupling Nut Torque	7 to 9.5 in-lbs	Coupling Proof Torque	6 to 10 in-lbs	Contact Captivation-axial	15 in-lbs	Durability (mating)	≥ 6.1 lbs		≥ 6.3 lbs		≥ 500		≥ 500
SMA	N																	
Recommended Coupling Nut Torque	7 to 9.5 in-lbs																	
Coupling Proof Torque	6 to 10 in-lbs																	
Contact Captivation-axial	15 in-lbs																	
Durability (mating)	≥ 6.1 lbs																	
	≥ 6.3 lbs																	
	≥ 500																	
	≥ 500																	
<div style="border: 1px solid black; padding: 2px; margin-bottom: 5px;">Environmental Data</div> Temperature Range Thermal Shock Moisture Resistance Corrosion RoHS	<table style="width: 100%;"> <tbody> <tr> <td style="width: 50%;">Temperature Range</td> <td style="width: 50%;">-65°C to +165°C</td> </tr> <tr> <td>Thermal Shock</td> <td>MIL-STD-202, Method 107, Condition B</td> </tr> <tr> <td>Moisture Resistance</td> <td>MIL-STD-202, Method 206</td> </tr> <tr> <td>Corrosion</td> <td>MIL-STD-202, Method 101, Condition B</td> </tr> <tr> <td>RoHS</td> <td>Compliant</td> </tr> </tbody> </table>		Temperature Range	-65°C to +165°C	Thermal Shock	MIL-STD-202, Method 107, Condition B	Moisture Resistance	MIL-STD-202, Method 206	Corrosion	MIL-STD-202, Method 101, Condition B	RoHS	Compliant						
Temperature Range	-65°C to +165°C																	
Thermal Shock	MIL-STD-202, Method 107, Condition B																	
Moisture Resistance	MIL-STD-202, Method 206																	
Corrosion	MIL-STD-202, Method 101, Condition B																	
RoHS	Compliant																	

Notice: JYEBAO reserves the right to make modifications deemed appropriate.

ADS-A8N8-18A-1.15

