

ADS-A8B3	Stainless SMA Jack To BNC Plug 7GHz VSWR 1.2; 12GHz VSWR 1.3	50Ω
----------	---	------------

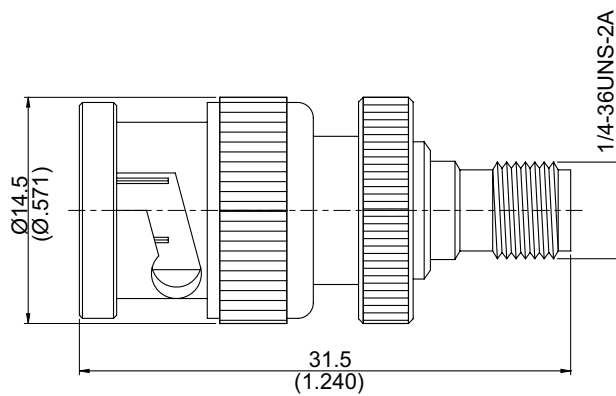

Parts	Material	Plating (Micro-inch)
Gasket	Silicon	
Washer	Brass	Tin-Zinc-Copper-Alloy 100 Over Copper 50
Spring	SK5	Tin-Zinc-Copper-Alloy 100 Over Copper 50
Body	Stainless Steel	Passivated
Contact Pin	Phosphor Bronze	Gold 4 Over Nickel-Phosphorus Alloy 80 Over Copper 20
Insulator	Teflon	
Coupling Nut	Stainless Steel	Passivated

Weight:

This part number complies with RoHS.

Notice: JYEBAO reserves the right to make modifications deemed appropriate.

ADS-A8B3	Stainless SMA Jack To BNC Plug 7GHz VSWR 1.2; 12GHz VSWR 1.3													
Interface Standard Mechanically compatible with	<table border="1"> <thead> <tr> <th>SMA</th> <th>BNC</th> </tr> </thead> <tbody> <tr> <td>MIL-STD-348B</td> <td>MIL-STD-348B</td> </tr> <tr> <td>2.92 & 3.5</td> <td></td> </tr> </tbody> </table>	SMA	BNC	MIL-STD-348B	MIL-STD-348B	2.92 & 3.5								
SMA	BNC													
MIL-STD-348B	MIL-STD-348B													
2.92 & 3.5														
Electrical Data Impedance Frequency Range VSWR Insertion Loss Insulation Resistance Dielectric Withstanding Voltage (at sea level) Working Voltage (at sea level)	<table> <tbody> <tr> <td>50Ω</td> </tr> <tr> <td>DC To 12GHz</td> </tr> <tr> <td>≤ 1.2 (7GHz); ≤ 1.3 (12GHz)</td> </tr> <tr> <td>≤ 0.05 x √f(GHz) dB</td> </tr> <tr> <td>≥ 5000MΩ</td> </tr> <tr> <td>1500 V rms</td> </tr> <tr> <td>500 V rms</td> </tr> </tbody> </table>		50Ω	DC To 12GHz	≤ 1.2 (7GHz); ≤ 1.3 (12GHz)	≤ 0.05 x √f(GHz) dB	≥ 5000MΩ	1500 V rms	500 V rms					
50Ω														
DC To 12GHz														
≤ 1.2 (7GHz); ≤ 1.3 (12GHz)														
≤ 0.05 x √f(GHz) dB														
≥ 5000MΩ														
1500 V rms														
500 V rms														
Mechanical Date Recommended Coupling Nut Torque Coupling Proof Torque Coupling Nut Retention Force Contact Captivation-axial Durability (mating)	<table border="1"> <thead> <tr> <th>SMA</th> <th>BNC</th> </tr> </thead> <tbody> <tr> <td>7 to 9.5 in-lbs</td> <td>0.6 to 2.5 in-lbs</td> </tr> <tr> <td>15 in-lbs</td> <td>NA</td> </tr> <tr> <td>NA</td> <td>≥ 101.2 lbs</td> </tr> <tr> <td>≥ 6.1 lbs</td> <td>≥ 6.1 lbs</td> </tr> <tr> <td>≥ 100</td> <td>≥ 500</td> </tr> </tbody> </table>		SMA	BNC	7 to 9.5 in-lbs	0.6 to 2.5 in-lbs	15 in-lbs	NA	NA	≥ 101.2 lbs	≥ 6.1 lbs	≥ 6.1 lbs	≥ 100	≥ 500
SMA	BNC													
7 to 9.5 in-lbs	0.6 to 2.5 in-lbs													
15 in-lbs	NA													
NA	≥ 101.2 lbs													
≥ 6.1 lbs	≥ 6.1 lbs													
≥ 100	≥ 500													
Environmental Data Temperature Range Thermal Shock Moisture Resistance Corrosion RoHS	<table> <tbody> <tr> <td>-65°C to +165°C</td> </tr> <tr> <td>MIL-STD-202, Method</td> </tr> <tr> <td>MIL-STD-202, Method</td> </tr> <tr> <td>MIL-STD-202, Method</td> </tr> <tr> <td>Compliant</td> </tr> </tbody> </table>		-65°C to +165°C	MIL-STD-202, Method	MIL-STD-202, Method	MIL-STD-202, Method	Compliant							
-65°C to +165°C														
MIL-STD-202, Method														
MIL-STD-202, Method														
MIL-STD-202, Method														
Compliant														

Notice: JYEBAO reserves the right to make modifications deemed appropriate.

ADS-A8B3

