

ADS-A3PC8-27-1.1	SMA Plug To 3.5 Jack 27GHz VSWR 1.1	50Ω
------------------	--	-----

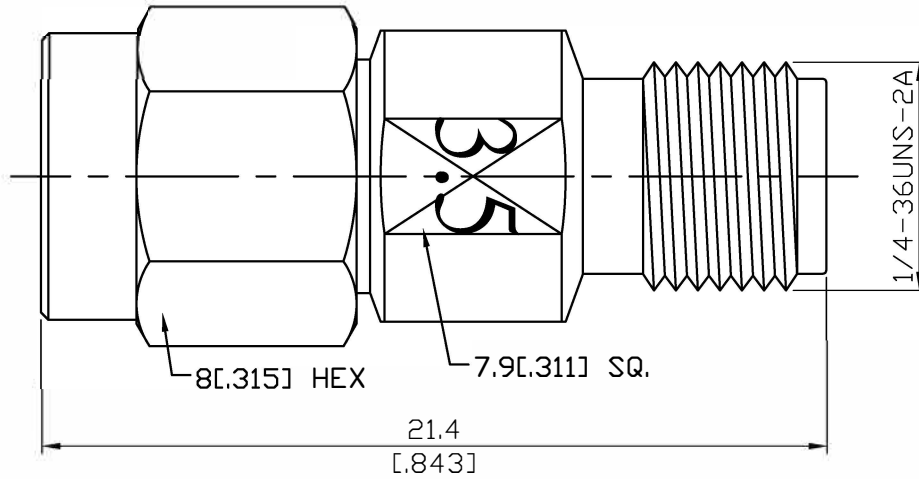

Parts	Material	Plating (Micro-inch)
Retainer Ring	Beryllium Copper	Tin-Zinc-Copper-Alloy 100 Over Copper 50
Gasket	Silicone	
Contact Pin	Beryllium Copper	Gold 4 Over Nickel-Phosphorus Alloy 80 Over Copper 20
Body	Stainless Steel	Passivated
Coupling Nut	Stainless Steel	Passivated
Insulator (SMA)	PTFE	
Insulator (3.5)	PPO	

--	--

This part number complies with RoHS.

Notice: JYEBAO reserves the right to make modifications deemed appropriate.

ADS-A3PC8-27-1.1	SMA Plug To 3.5 Jack 27GHz VSWR 1.1															
<div style="border: 1px solid black; padding: 2px; margin-bottom: 5px;">Interface</div> Standard Mechanically compatible with	<table border="1" style="width: 100%; border-collapse: collapse;"> <thead> <tr> <th style="width: 50%;">3.5</th> <th style="width: 50%;">SMA</th> </tr> </thead> <tbody> <tr> <td>IEC60169-23</td> <td>MIL-STD-348B</td> </tr> <tr> <td>2.92 & SMA</td> <td>2.92 & 3.5</td> </tr> </tbody> </table>	3.5	SMA	IEC60169-23	MIL-STD-348B	2.92 & SMA	2.92 & 3.5									
3.5	SMA															
IEC60169-23	MIL-STD-348B															
2.92 & SMA	2.92 & 3.5															
<div style="border: 1px solid black; padding: 2px; margin-bottom: 5px;">Electrical Data</div> Impedance Frequency Range VSWR Insertion Loss Insulation Resistance Dielectric Withstanding Voltage (at sea level) Working Voltage (at sea level)	<table style="width: 100%;"> <tbody> <tr> <td style="width: 50%;">50Ω</td> <td style="width: 50%;"></td> </tr> <tr> <td>DC To 27GHz</td> <td></td> </tr> <tr> <td>≤ 1.1 (DC To 27GHz)</td> <td></td> </tr> <tr> <td>≤ 0.05 x √f(GHz) dB</td> <td></td> </tr> <tr> <td>≥ 5000MΩ</td> <td></td> </tr> <tr> <td>1000 V rms</td> <td></td> </tr> <tr> <td>335 V rms</td> <td></td> </tr> </tbody> </table>		50Ω		DC To 27GHz		≤ 1.1 (DC To 27GHz)		≤ 0.05 x √f(GHz) dB		≥ 5000MΩ		1000 V rms		335 V rms	
50Ω																
DC To 27GHz																
≤ 1.1 (DC To 27GHz)																
≤ 0.05 x √f(GHz) dB																
≥ 5000MΩ																
1000 V rms																
335 V rms																
<div style="border: 1px solid black; padding: 2px; margin-bottom: 5px;">Mechanical Data</div> Recommended Coupling Nut Torque Coupling Proof Torque Coupling nut retention force Contact Captivation-axial Durability (mating)	<table border="1" style="width: 100%; border-collapse: collapse;"> <thead> <tr> <th style="width: 50%;">3.5</th> <th style="width: 50%;">SMA</th> </tr> </thead> <tbody> <tr> <td>7.1 to 9.7 in-lbs</td> <td>7.5 to 9.5 in-lbs</td> </tr> <tr> <td>15 in-lbs</td> <td>15 in-lbs</td> </tr> <tr> <td>NA</td> <td>≥ 60.7 lbs</td> </tr> <tr> <td>≥ 6.1 lbs</td> <td>≥ 6.1 lbs</td> </tr> <tr> <td>≥ 500</td> <td>≥ 500</td> </tr> </tbody> </table>		3.5	SMA	7.1 to 9.7 in-lbs	7.5 to 9.5 in-lbs	15 in-lbs	15 in-lbs	NA	≥ 60.7 lbs	≥ 6.1 lbs	≥ 6.1 lbs	≥ 500	≥ 500		
3.5	SMA															
7.1 to 9.7 in-lbs	7.5 to 9.5 in-lbs															
15 in-lbs	15 in-lbs															
NA	≥ 60.7 lbs															
≥ 6.1 lbs	≥ 6.1 lbs															
≥ 500	≥ 500															
<div style="border: 1px solid black; padding: 2px; margin-bottom: 5px;">Environmental Data</div> Temperature Range Thermal Shock Moisture Resistance Corrosion RoHS	<table style="width: 100%;"> <tbody> <tr> <td style="width: 50%;">-55°C to +105°C</td> <td style="width: 50%;"></td> </tr> <tr> <td>MIL-STD-202, Method 107, Condition B</td> <td></td> </tr> <tr> <td>MIL-STD-202, Method 206</td> <td></td> </tr> <tr> <td>MIL-STD-202, Method 101, Condition B</td> <td></td> </tr> <tr> <td>Compliant</td> <td></td> </tr> </tbody> </table>		-55°C to +105°C		MIL-STD-202, Method 107, Condition B		MIL-STD-202, Method 206		MIL-STD-202, Method 101, Condition B		Compliant					
-55°C to +105°C																
MIL-STD-202, Method 107, Condition B																
MIL-STD-202, Method 206																
MIL-STD-202, Method 101, Condition B																
Compliant																

ADS-A3PC8-27-1.1

