

| | | |
|------------------|--|-----|
| ADS-A3PC3-27-1.1 | SMA Plug To 3.5 Plug 27GHz VSWR 1.1 | 50Ω |
|------------------|--|-----|

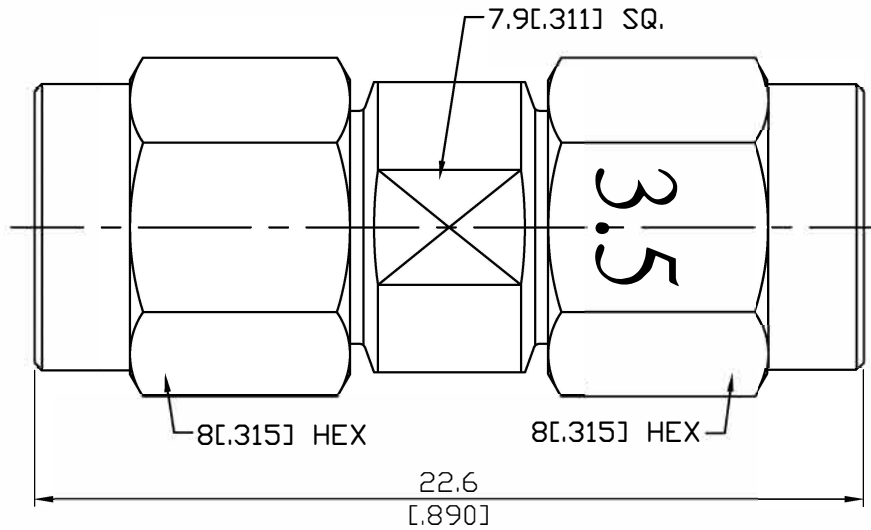

| Parts | Material | Plating (Micro-inch) |
|-----------------|------------------|---|
| Retainer Ring | Beryllium Copper | Tin-Zinc-Copper-Alloy 100 Over Copper 50 |
| Gasket | Silicone | |
| Contact Pin | Beryllium Copper | Gold 4 Over Nickel-Phosphorus Alloy 80 Over Copper 20 |
| Body | Stainless Steel | Passivated |
| Coupling Nut | Stainless Steel | Passivated |
| Insulator (SMA) | PTFE | |
| Insulator (3.5) | PPO | |

| | |
|---------|--|
| Weight: | |
|---------|--|

This part number complies with RoHS.

Notice: JYEBAO reserves the right to make modifications deemed appropriate.

| ADS-A3PC3-27-1.1 | SMA Plug To 3.5 Plug 27GHz VSWR 1.1 | |
|---|---|---|
| Interface Standard Mechanically compatible with | 3.5 IEC60169-23 2.92 & SMA | SMA MIL-STD-348B 2.92 & 3.5 |
| Electrical Data Impedance Frequency Range VSWR Insertion Loss Insulation Resistance Dielectric Withstanding Voltage (at sea level) Working Voltage (at sea level) | 50Ω DC To 27GHz ≤ 1.1 (DC To 27GHz) ≤ 0.05 x √f(GHz) dB ≥ 5000MΩ 1000 V rms 335 V rms | |
| Mechanical Data Recommended Coupling Nut Torque Coupling Proof Torque Coupling nut retention force Contact Captivation-axial Durability (mating) | 3.5 7.1 to 9.7 in-lbs 15 in-lbs ≥ 60.7 lbs ≥ 6.1 lbs ≥ 500 | SMA 7.5 to 9.5 in-lbs 15 in-lbs ≥ 60.7 lbs ≥ 6.1 lbs ≥ 500 |
| Environmental Data Temperature Range Thermal Shock Moisture Resistance Corrosion RoHS | -55°C to +105°C MIL-STD-202, Method 107, Condition B MIL-STD-202, Method 206 MIL-STD-202, Method 101, Condition B Compliant | |

ADS-A3PC3-27-1.1

