

ADS-A3N3-P4-18-1.2	SMA Plug To N Plug 4 Hole Flange 18GHz VSWR 1.2	50Ω
--------------------	--	-----

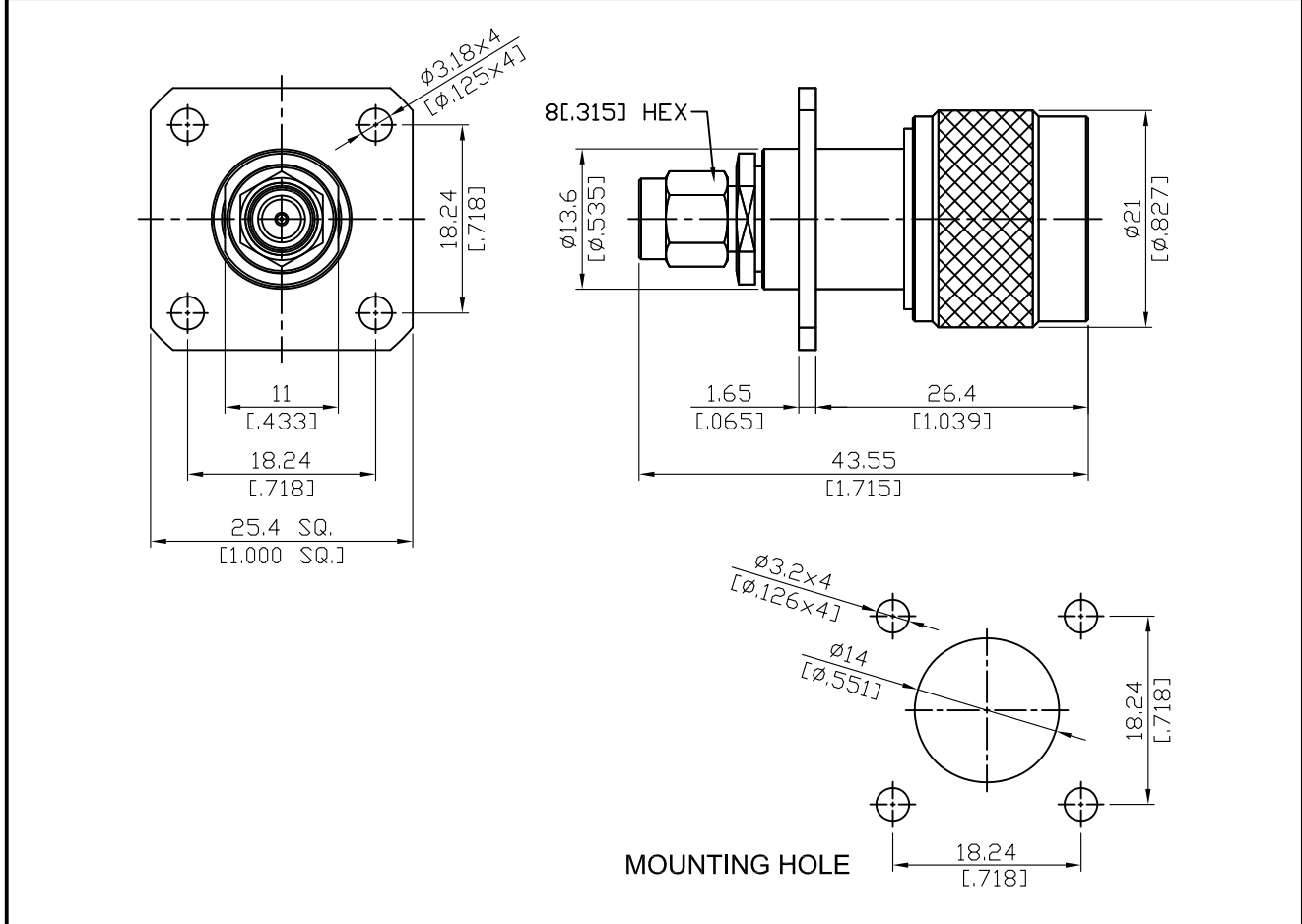

Parts	Material	Plating (Micro-inch)
Retainer Ring	Brass	Tin-Zinc-Copper-Alloy 100 Over Copper 50
Insulator (N)	PPO	
Contact Pin	Beryllium Copper	Gold 4 Over Nickel-Phosphorus Alloy 80 Over Copper 20
Retainer Ring	Beryllium Copper	Tin-Zinc-Copper-Alloy 100 Over Copper 50
Gasket	Silicone	
Insulator (SMA)	Teflon	
Body	Stainless Steel	Passivated
Coupling Nut	Stainless Steel	Passivated

--	--

This part number complies with RoHS.
 Notice: JYEBAO reserves the right to make modifications deemed appropriate.

ADS-A3N3-P4-18-1.2	SMA Plug To N Plug 4 Hole Flange 18GHz VSWR 1.2	
Interface Standard Mechanically compatible with	SMA MIL-STD-348B 2.92 & 3.5	N MIL-STD-348B
Electrical Data Impedance Frequency Range VSWR Insertion Loss Insulation Resistance Dielectric Withstanding Voltage (at sea level) Working Voltage (at sea level)	50Ω DC To 18GHz ≤ 1.2 (DC To 18GHz) ≤ 0.04 x √f(GHz) dB ≥ 5000MΩ 1500 V rms 500 V rms	
Mechanical Data Recommended Coupling Nut Torque Coupling Proof Torque Coupling Nut Retention Force Contact Captivation-axial Durability (mating)	SMA 7 to 9.5 in-lbs 15 in-lbs ≥ 60.7 lbs ≥ 6.1 lbs ≥ 500	N 6 to 10 in-lbs 15 in-lbs ≥ 101.2 lbs ≥ 6.3 lbs ≥ 500
Environmental Data Temperature Range Thermal Shock Moisture Resistance Corrosion RoHS	-55°C to +105°C MIL-STD-202, Method 107, Condition B MIL-STD-202, Method 206 MIL-STD-202, Method 101, Condition B Compliant	

Notice: JYEBAO reserves the right to make modifications deemed appropriate.

ADS-A3N3-P4-18-1.2

