

ADS-A3AQ8

SMA Plug To Snap On SMA Jack  
18GHz VSWR1.2

50Ω

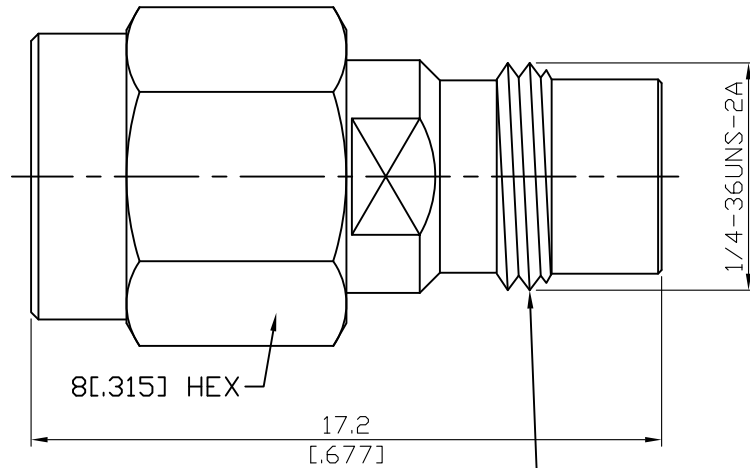

\*SMA Jack Snap On Design With Short Thread Ensuring Excellent Mating Reliability  
\*Snap On And Give One Turn For Proper Mating

Parts	Material	Plating ( Micro-inch )
Retainer Ring	Beryllium Copper	Tin-Zinc-Copper-Alloy 100 Over Copper 50
Gasket	Silicone	
Contact Pin	Beryllium Copper	Gold 4 Over Nickel-Phosphorus Alloy 80 Over Copper 20
Insulator	Teflon	
Body	Stainless Steel	Passivated
Coupling Nut	Stainless Steel	Passivated

This part number complies with RoHS.

Notice: JYEBAO reserves the right to make modifications deemed appropriate.

ADS-A3AQ8	SMA Plug To Snap On SMA Jack 18GHz VSWR1.2															
<div style="border: 1px solid black; padding: 2px; margin-bottom: 5px;">Interface</div> Standard Mechanically compatible with	SMA Plug Screw Side <hr/> MIL-STD-348B 2.92 & 3.5	SMA Jack Snap On Side <hr/> Per JYEBAO Snap On SMA Jack 2.92 & 3.5														
<div style="border: 1px solid black; padding: 2px; margin-bottom: 5px;">Electrical Data</div> <table style="width: 100%; border-collapse: collapse;"> <tr> <td style="width: 50%;">Impedance</td> <td style="width: 50%;">50Ω</td> </tr> <tr> <td>Frequency Range</td> <td>DC To 18GHz</td> </tr> <tr> <td>VSWR</td> <td>≤ 1.2 (DC To 18GHz)</td> </tr> <tr> <td>Insertion Loss</td> <td>≤ 0.04 x √f(GHz) dB</td> </tr> <tr> <td>Insulation Resistance</td> <td>≥ 5000MΩ</td> </tr> <tr> <td>Dielectric Withstanding Voltage (at sea level)</td> <td>1500 V rms</td> </tr> <tr> <td>Working Voltage (at sea level)</td> <td>500 V rms</td> </tr> </table>			Impedance	50Ω	Frequency Range	DC To 18GHz	VSWR	≤ 1.2 (DC To 18GHz)	Insertion Loss	≤ 0.04 x √f(GHz) dB	Insulation Resistance	≥ 5000MΩ	Dielectric Withstanding Voltage (at sea level)	1500 V rms	Working Voltage (at sea level)	500 V rms
Impedance	50Ω															
Frequency Range	DC To 18GHz															
VSWR	≤ 1.2 (DC To 18GHz)															
Insertion Loss	≤ 0.04 x √f(GHz) dB															
Insulation Resistance	≥ 5000MΩ															
Dielectric Withstanding Voltage (at sea level)	1500 V rms															
Working Voltage (at sea level)	500 V rms															
<div style="border: 1px solid black; padding: 2px; margin-bottom: 5px;">Mechanical Data</div> <table style="width: 100%; border-collapse: collapse;"> <tr> <td style="width: 50%;">Recommended Coupling Nut Torque</td> <td style="width: 50%;">7 to 9.5 in-lbs (Not applicable to snap on side)</td> </tr> <tr> <td>Coupling Proof Torque</td> <td>15 in-lbs (Not applicable to snap on side)</td> </tr> <tr> <td>Coupling Nut Retention Force</td> <td>≥ 60.7 lbs</td> </tr> <tr> <td>Contact Captivation-axial</td> <td>≥ 6.1 lbs</td> </tr> <tr> <td>Durability (mating)</td> <td>≥ 500</td> </tr> </table>			Recommended Coupling Nut Torque	7 to 9.5 in-lbs (Not applicable to snap on side)	Coupling Proof Torque	15 in-lbs (Not applicable to snap on side)	Coupling Nut Retention Force	≥ 60.7 lbs	Contact Captivation-axial	≥ 6.1 lbs	Durability (mating)	≥ 500				
Recommended Coupling Nut Torque	7 to 9.5 in-lbs (Not applicable to snap on side)															
Coupling Proof Torque	15 in-lbs (Not applicable to snap on side)															
Coupling Nut Retention Force	≥ 60.7 lbs															
Contact Captivation-axial	≥ 6.1 lbs															
Durability (mating)	≥ 500															
<div style="border: 1px solid black; padding: 2px; margin-bottom: 5px;">Environmental Data</div> <table style="width: 100%; border-collapse: collapse;"> <tr> <td style="width: 50%;">Temperature Range</td> <td style="width: 50%;">-65°C to +165°C</td> </tr> <tr> <td>Thermal Shock</td> <td>MIL-STD-202, Method 107, Condition B</td> </tr> <tr> <td>Moisture Resistance</td> <td>MIL-STD-202, Method 206</td> </tr> <tr> <td>Corrosion</td> <td>MIL-STD-202, Method 101, Condition B</td> </tr> <tr> <td>RoHS</td> <td>Compliant</td> </tr> </table>			Temperature Range	-65°C to +165°C	Thermal Shock	MIL-STD-202, Method 107, Condition B	Moisture Resistance	MIL-STD-202, Method 206	Corrosion	MIL-STD-202, Method 101, Condition B	RoHS	Compliant				
Temperature Range	-65°C to +165°C															
Thermal Shock	MIL-STD-202, Method 107, Condition B															
Moisture Resistance	MIL-STD-202, Method 206															
Corrosion	MIL-STD-202, Method 101, Condition B															
RoHS	Compliant															

Notice: JYEBAO reserves the right to make modifications deemed appropriate.

# ADS-A3AQ8

