

ADS-24/8-24/8-BF-GBV-1.25

Hermetic 1×10^{-8} atm cc/sec & Bulkhead side thermo vacuum 1×10^{-6} Torr
2.4mm Jack to 2.4mm Jack Bulkhead; 50GHz VSWR 1.25

50Ω

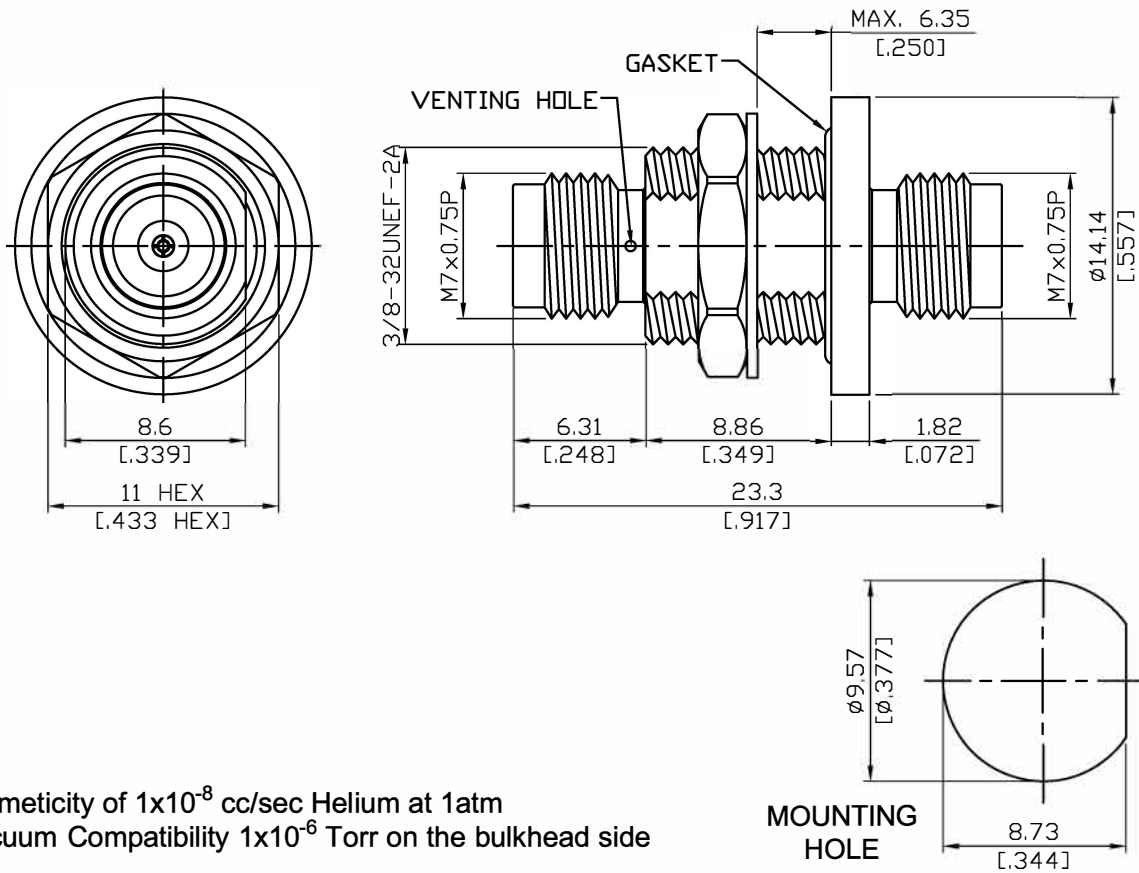

Parts	Material	Plating (Micro-inch)
Hex Nut	Stainless Steel	Passivated
Lock Washer	Stainless Steel	Passivated
Gasket	VITON	
Glass Seal	Kovar+Glass	Gold 4 Over Nickel-Phosphorus Alloy 80 Over Copper 20
Contact Pin	Beryllium Copper	Gold 4 Over Nickel-Phosphorus Alloy 80 Over Copper 20
Insulator	PEI	
Body	Stainless Steel	Gold 5 Over Nickel-Phosphorus Alloy 50 Over Copper 50
Body	Stainless Steel	Passivated

This part number complies with RoHS.

Notice: JYEBAO reserves the right to make modifications deemed appropriate.

ADS-24/8-24/8-BF-GBV-1.25

Hermetic 1×10^{-8} atm cc/sec & Bulkhead side thermo vacuum 1×10^{-6} Torr
2.4mm Jack to 2.4mm Jack Bulkhead; 50GHz VSWR 1.25

Interface

Standard	MIL-STD-348B
Mechanically compatible with	1.85

Electrical Data

Impedance	50Ω
Frequency Range	DC to 50GHz
VSWR	≤ 1.25 (DC to 50GHz)
Insertion Loss	$\leq 0.08 \times \sqrt{f(\text{GHz})}$ dB
Insulation Resistance	$\geq 5000\text{M}\Omega$
Dielectric Withstanding Voltage (at sea level)	500 V rms
Working Voltage (at sea level)	150 V rms

Mechanical Data

Recommended Coupling Nut Torque	7.08 to 9.74 inch lbs
Coupling Proof Torque	15 inch lbs
Contact Captivation-axial	≥ 4.5 lbs
Durability (mating)	≥ 500

Environmental Data

Temperature Range	-10°C to +165°C
Thermal Shock	MIL-STD-202, Method 107, Condition B
Moisture Resistance	MIL-STD-202, Method 206
Corrosion	MIL-STD-202, Method 101, Condition B
RoHS	Compliant

ADS-24/8-24/8-BF-GBV-1.25

