

ADS-2.4/8-2.4/8-BFA1.15

2.4mm Jack To 2.4mm Jack Bulkhead  
IP67 Mated; 50GHz VSWR 1.15

50Ω

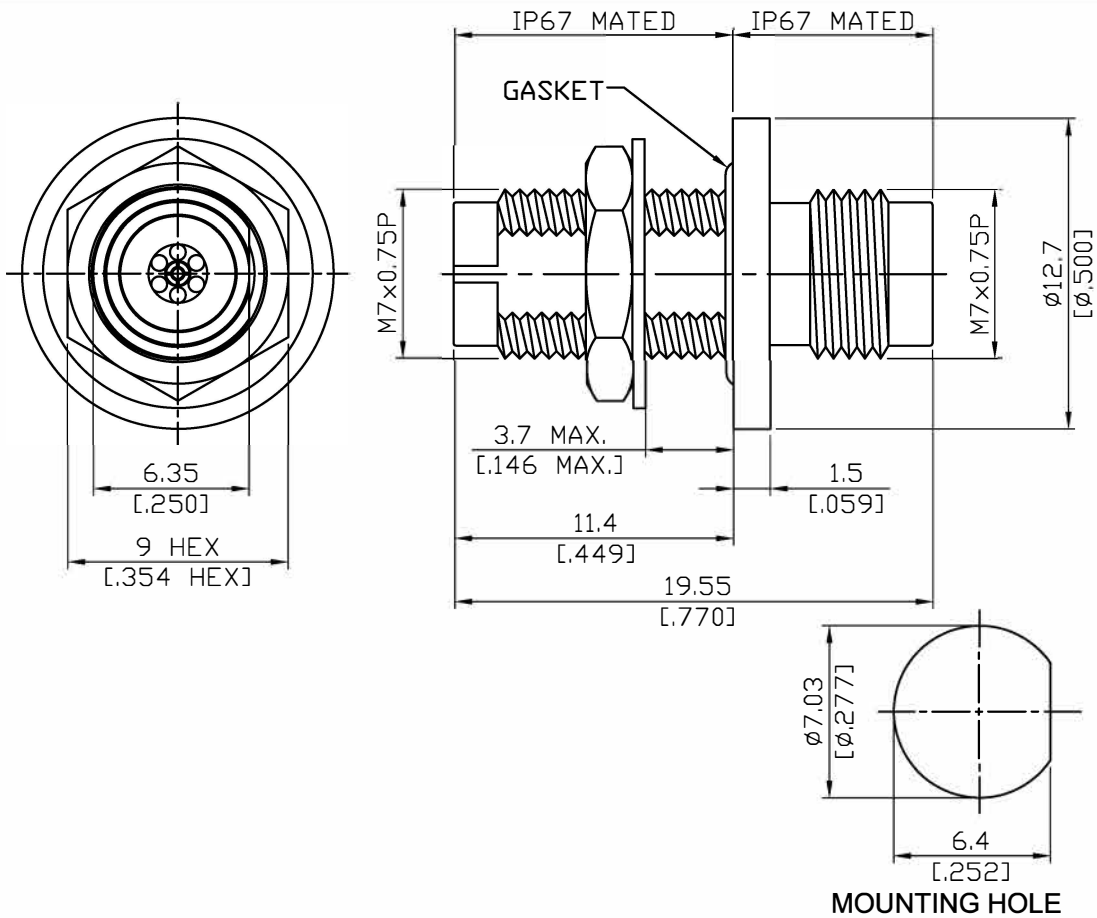

Parts	Material	Plating ( Micro-inch )
Hex Nut	Stainless Steel	Passivated
Lock Washer	Stainless Steel	Passivated
Gasket	Silicone	
Contact Pin	Beryllium Copper	Gold 4 Over Nickel-Phosphorus Alloy 80 Over Copper 20
Insulator	PPO	
Body	Stainless Steel	Passivated

This part number complies with RoHS.

Notice: JYEBAO reserves the right to make modifications deemed appropriate.

ADS-24/8-24/8-BFA1.15	2.4mm Jack To 2.4mm Jack Bulkhead IP67 Mated; 50GHz VSWR 1.15
<b>Interface</b> Standard MIL-STD-348B Mechanically compatible with 1.85	
<b>Electrical Data</b> Impedance 50Ω Frequency Range DC to 50GHz VSWR $\leq 1.15$ (DC to 50GHz) Insertion Loss $\leq 0.04 \times \sqrt{f(\text{GHz})}$ dB Insulation Resistance $\geq 5000\text{M}\Omega$ Dielectric Withstanding Voltage (at sea level) 500 V rms Working Voltage (at sea level) 150 V rms RF Leakage $\geq 100\text{dB}$ to 1GHz	
<b>Mechanical Data</b> Recommended Coupling Nut Torque 7.08 to 9.74 inch lbs Coupling Proof Torque 15 inch lbs Contact Captivation-axial $\geq 4.5$ lbs Durability (mating) $\geq 500$	
<b>Environmental Data</b> Temperature Range -55°C to +105°C Thermal Shock MIL-STD-202, Method 107, Condition B Moisture Resistance MIL-STD-202, Method 206 Corrosion MIL-STD-202, Method 101, Condition B RoHS Compliant	

Notice: JYEBAO reserves the right to make modifications deemed appropriate.

# ADS-2.4/8-2.4/8-BFA1.15

Tr1 S11 Refl SWR RefLvl: 1 U Res: 50 mU/Div

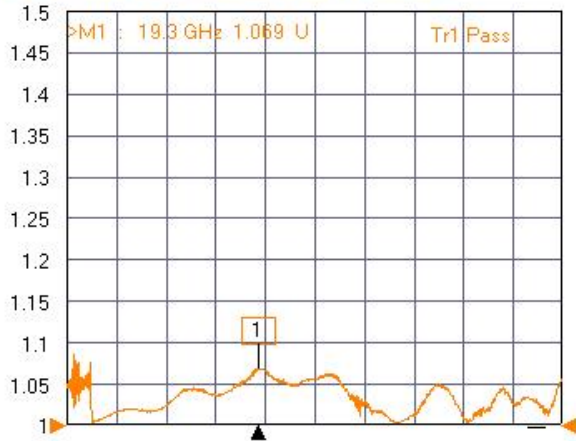

Tr2 S21 Trans LogM RefLvl: 0 dB Res: 0.1 dB/Div

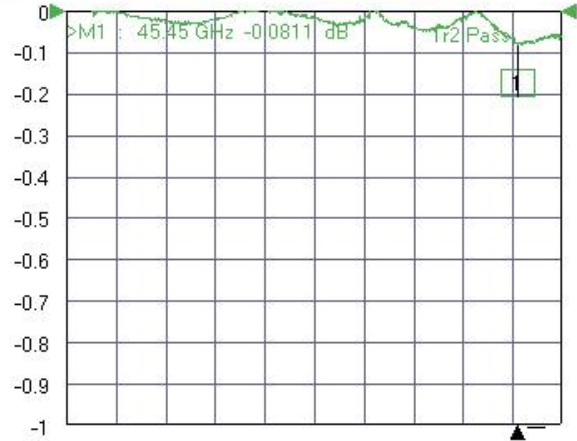

Tr3 S22 Refl SWR RefLvl: 1 U Res: 50 mU/Div

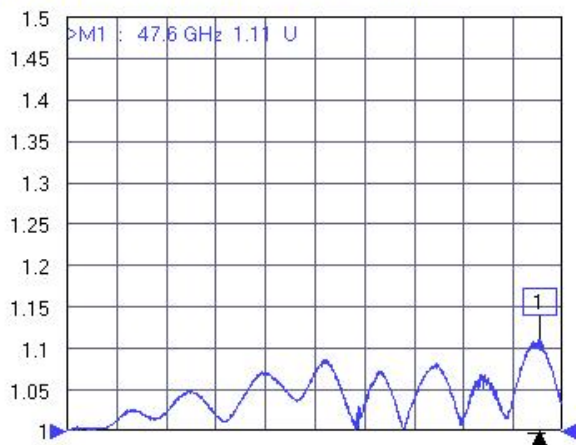

Tr4 S12 Trans LogM RefLvl: 0 dB Res: 0.1 dB/Div

