

ADS-18/8-18/8-BFA1.2	1.85mm Jack to 1.85mm Jack Bulkhead IP67 Mated, 67GHz VSWR 1.25	50Ω
-----------------------------	--	------------

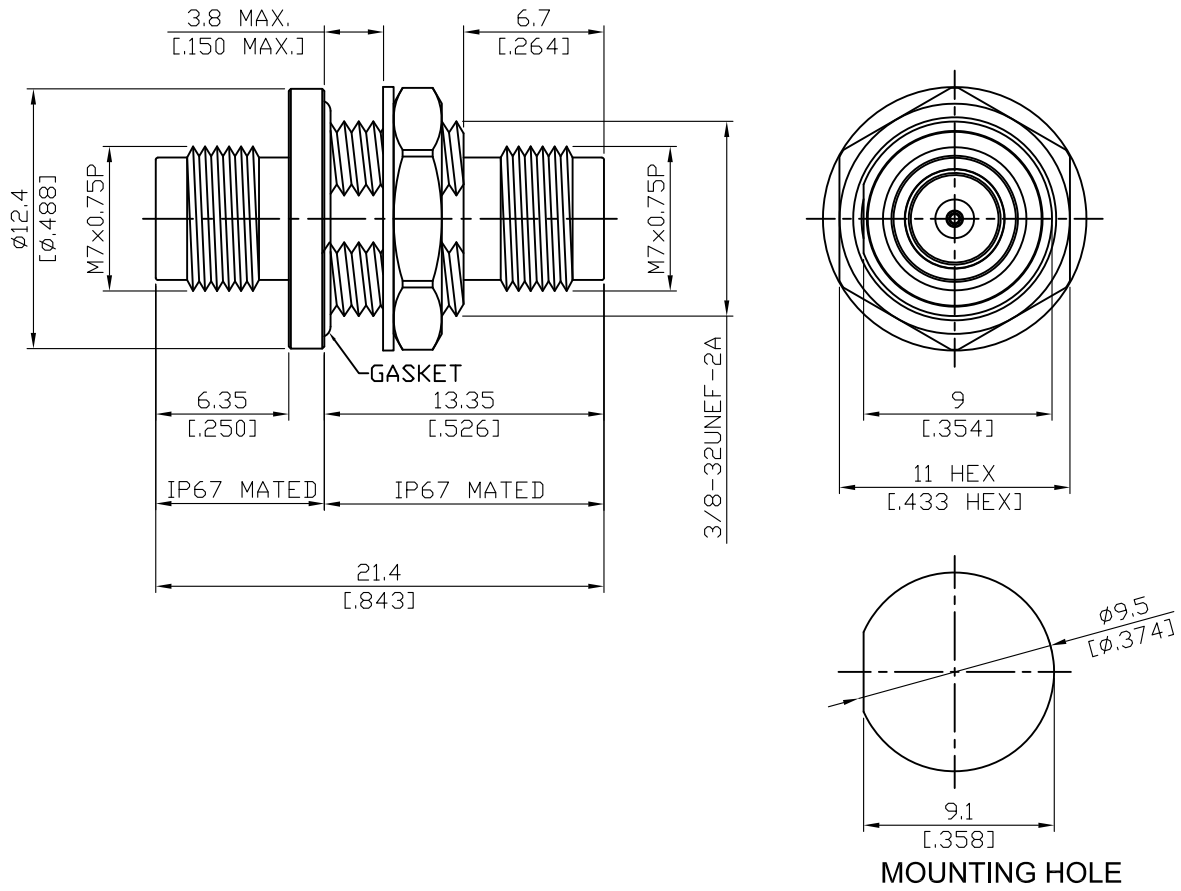

Parts	Material	Plating (Micro-inch)
Body	Stainless Steel	Passivated
Insulator	PPO	
Contact Pin	Beryllium Copper	Gold 4 Over Nickel-Phosphorus Alloy 80 Over Copper 20
Gasket	Silicone	
Lock Washer	Stainless Steel	Passivated
Hex Nut	Stainless Steel	Passivated

--	--

This part number complies with RoHS.
 Notice: JYEBAO reserves the right to make modifications deemed appropriate.

ADS-18/8-18/8-BFA1.2	1.85mm Jack to 1.85mm Jack Bulkhead IP67 Mated, 67GHz VSWR 1.25																		
<table border="0"> <tr> <td colspan="2" data-bbox="129 344 531 394">Interface</td> </tr> <tr> <td data-bbox="129 405 791 439">Standard</td> <td data-bbox="791 405 1481 439">IEEE287; IEC61169-32</td> </tr> <tr> <td data-bbox="129 450 791 483">Mechanically compatible with</td> <td data-bbox="791 450 1481 483">2.4</td> </tr> </table>		Interface		Standard	IEEE287; IEC61169-32	Mechanically compatible with	2.4												
Interface																			
Standard	IEEE287; IEC61169-32																		
Mechanically compatible with	2.4																		
<table border="0"> <tr> <td colspan="2" data-bbox="129 607 531 656">Electrical Data</td> </tr> <tr> <td data-bbox="129 667 791 701">Impedance</td> <td data-bbox="791 667 1481 701">50Ω</td> </tr> <tr> <td data-bbox="129 712 791 745">Frequency Range</td> <td data-bbox="791 712 1481 745">DC to 67GHz</td> </tr> <tr> <td data-bbox="129 757 791 790">VSWR</td> <td data-bbox="791 757 1481 790">≤ 1.25 (DC To 67GHz)</td> </tr> <tr> <td data-bbox="129 801 791 835">Insertion Loss</td> <td data-bbox="791 801 1481 835">≤ 0.05 x √f(GHz) dB</td> </tr> <tr> <td data-bbox="129 846 791 880">Insulation Resistance</td> <td data-bbox="791 846 1481 880">≥ 5000MΩ</td> </tr> <tr> <td data-bbox="129 891 791 925">Dielectric Withstanding Voltage (at sea level)</td> <td data-bbox="791 891 1481 925">500 V rms</td> </tr> <tr> <td data-bbox="129 936 791 969">Working Voltage (at sea level)</td> <td data-bbox="791 936 1481 969">150 V rms</td> </tr> <tr> <td data-bbox="129 981 791 1014">RF Leakage</td> <td data-bbox="791 981 1481 1014">≥ 100 dB to 1GHz</td> </tr> </table>		Electrical Data		Impedance	50Ω	Frequency Range	DC to 67GHz	VSWR	≤ 1.25 (DC To 67GHz)	Insertion Loss	≤ 0.05 x √f(GHz) dB	Insulation Resistance	≥ 5000MΩ	Dielectric Withstanding Voltage (at sea level)	500 V rms	Working Voltage (at sea level)	150 V rms	RF Leakage	≥ 100 dB to 1GHz
Electrical Data																			
Impedance	50Ω																		
Frequency Range	DC to 67GHz																		
VSWR	≤ 1.25 (DC To 67GHz)																		
Insertion Loss	≤ 0.05 x √f(GHz) dB																		
Insulation Resistance	≥ 5000MΩ																		
Dielectric Withstanding Voltage (at sea level)	500 V rms																		
Working Voltage (at sea level)	150 V rms																		
RF Leakage	≥ 100 dB to 1GHz																		
<table border="0"> <tr> <td colspan="2" data-bbox="129 1155 531 1205">Mechanical Data</td> </tr> <tr> <td data-bbox="129 1216 791 1249">Recommended Coupling Nut Torque</td> <td data-bbox="791 1216 1481 1249">7.08 to 9.74 inch lbs</td> </tr> <tr> <td data-bbox="129 1261 791 1294">Coupling Proof Torque</td> <td data-bbox="791 1261 1481 1294">15 inch-lbs</td> </tr> <tr> <td data-bbox="129 1305 791 1339">Contact Captivation-axial</td> <td data-bbox="791 1305 1481 1339">≥ 4.5 lbs</td> </tr> <tr> <td data-bbox="129 1350 791 1384">Durability (mating)</td> <td data-bbox="791 1350 1481 1384">≥ 500</td> </tr> </table>		Mechanical Data		Recommended Coupling Nut Torque	7.08 to 9.74 inch lbs	Coupling Proof Torque	15 inch-lbs	Contact Captivation-axial	≥ 4.5 lbs	Durability (mating)	≥ 500								
Mechanical Data																			
Recommended Coupling Nut Torque	7.08 to 9.74 inch lbs																		
Coupling Proof Torque	15 inch-lbs																		
Contact Captivation-axial	≥ 4.5 lbs																		
Durability (mating)	≥ 500																		
<table border="0"> <tr> <td colspan="2" data-bbox="129 1507 531 1556">Environmental Data</td> </tr> <tr> <td data-bbox="129 1563 791 1597">Temperature Range</td> <td data-bbox="791 1563 1481 1597">-55°C to +105°C</td> </tr> <tr> <td data-bbox="129 1608 791 1641">Thermal Shock</td> <td data-bbox="791 1608 1481 1641">MIL-STD-202, Method 107, Condition B</td> </tr> <tr> <td data-bbox="129 1653 791 1686">Moisture Resistance</td> <td data-bbox="791 1653 1481 1686">MIL-STD-202, Method 206</td> </tr> <tr> <td data-bbox="129 1697 791 1731">Corrosion</td> <td data-bbox="791 1697 1481 1731">MIL-STD-202, Method 101, Condition B</td> </tr> <tr> <td data-bbox="129 1742 791 1776">RoHS</td> <td data-bbox="791 1742 1481 1776">Compliant</td> </tr> </table>		Environmental Data		Temperature Range	-55°C to +105°C	Thermal Shock	MIL-STD-202, Method 107, Condition B	Moisture Resistance	MIL-STD-202, Method 206	Corrosion	MIL-STD-202, Method 101, Condition B	RoHS	Compliant						
Environmental Data																			
Temperature Range	-55°C to +105°C																		
Thermal Shock	MIL-STD-202, Method 107, Condition B																		
Moisture Resistance	MIL-STD-202, Method 206																		
Corrosion	MIL-STD-202, Method 101, Condition B																		
RoHS	Compliant																		

ADS-18/8-18/8-BFA1.2

