

ADS-18/8-18/8-BFA1.15	1.85mm Jack to 1.85mm Jack Bulkhead IP67 Mated, 67GHz VSWR 1.15	50Ω
-----------------------	--	-----

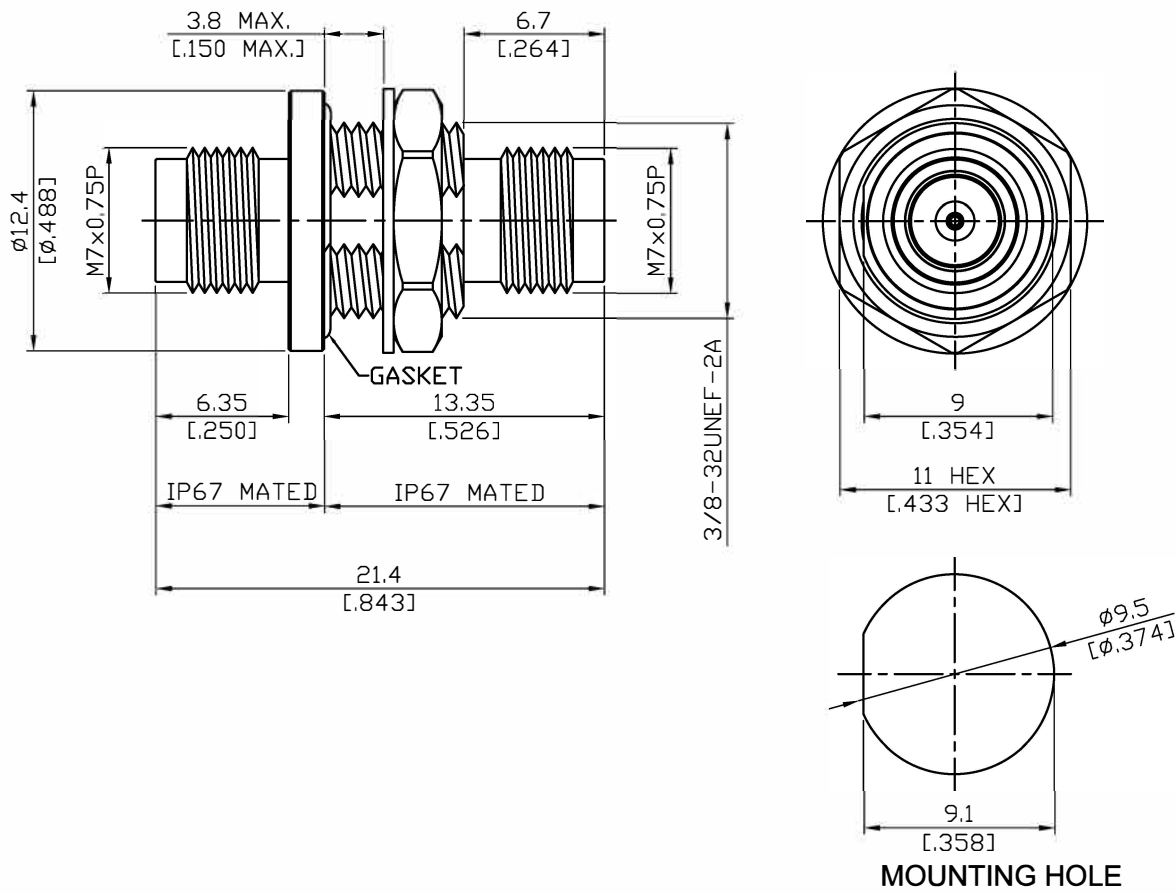

Parts	Material	Plating (Micro-inch)
Body	Stainless Steel	Passivated
Insulator	PPO	
Contact Pin	Beryllium Copper	Gold 4 Over Nickel-Phosphorus Alloy 80 Over Copper 20
Gasket	Silicone	
Lock Washer	Stainless Steel	Passivated
Hex Nut	Stainless Steel	Passivated

This part number complies with RoHS.

Notice: JYEBAO reserves the right to make modifications deemed appropriate.

ADS-18/8-18/8-BFA1.15	1.85mm Jack to 1.85mm Jack Bulkhead IP67 Mated, 67GHz VSWR 1.15																		
<table border="0"> <tr> <td colspan="2" data-bbox="129 344 531 394">Interface</td> </tr> <tr> <td data-bbox="129 405 774 439">Standard</td> <td data-bbox="794 405 1134 439">IEEE287; IEC61169-32</td> </tr> <tr> <td data-bbox="129 450 774 483">Mechanically compatible with</td> <td data-bbox="794 450 842 483">2.4</td> </tr> </table>		Interface		Standard	IEEE287; IEC61169-32	Mechanically compatible with	2.4												
Interface																			
Standard	IEEE287; IEC61169-32																		
Mechanically compatible with	2.4																		
<table border="0"> <tr> <td colspan="2" data-bbox="129 607 531 656">Electrical Data</td> </tr> <tr> <td data-bbox="129 667 774 701">Impedance</td> <td data-bbox="794 667 858 701">50Ω</td> </tr> <tr> <td data-bbox="129 712 774 745">Frequency Range</td> <td data-bbox="794 712 991 745">DC to 67GHz</td> </tr> <tr> <td data-bbox="129 757 774 790">VSWR</td> <td data-bbox="794 757 1126 790">≤ 1.15 (DC To 67GHz)</td> </tr> <tr> <td data-bbox="129 801 774 835">Insertion Loss</td> <td data-bbox="794 801 1086 835">≤ 0.05 x √f(GHz) dB</td> </tr> <tr> <td data-bbox="129 846 774 880">Insulation Resistance</td> <td data-bbox="794 846 954 880">≥ 5000MΩ</td> </tr> <tr> <td data-bbox="129 891 774 925">Dielectric Withstanding Voltage (at sea level)</td> <td data-bbox="794 891 946 925">500 V rms</td> </tr> <tr> <td data-bbox="129 936 774 969">Working Voltage (at sea level)</td> <td data-bbox="794 936 946 969">150 V rms</td> </tr> <tr> <td data-bbox="129 981 774 1014">RF Leakage</td> <td data-bbox="794 981 1062 1014">≥ 100 dB to 1GHz</td> </tr> </table>		Electrical Data		Impedance	50Ω	Frequency Range	DC to 67GHz	VSWR	≤ 1.15 (DC To 67GHz)	Insertion Loss	≤ 0.05 x √f(GHz) dB	Insulation Resistance	≥ 5000MΩ	Dielectric Withstanding Voltage (at sea level)	500 V rms	Working Voltage (at sea level)	150 V rms	RF Leakage	≥ 100 dB to 1GHz
Electrical Data																			
Impedance	50Ω																		
Frequency Range	DC to 67GHz																		
VSWR	≤ 1.15 (DC To 67GHz)																		
Insertion Loss	≤ 0.05 x √f(GHz) dB																		
Insulation Resistance	≥ 5000MΩ																		
Dielectric Withstanding Voltage (at sea level)	500 V rms																		
Working Voltage (at sea level)	150 V rms																		
RF Leakage	≥ 100 dB to 1GHz																		
<table border="0"> <tr> <td colspan="2" data-bbox="129 1155 531 1205">Mechanical Data</td> </tr> <tr> <td data-bbox="129 1216 774 1249">Recommended Coupling Nut Torque</td> <td data-bbox="794 1216 1086 1249">7.08 to 9.74 inch lbs</td> </tr> <tr> <td data-bbox="129 1261 774 1294">Coupling Proof Torque</td> <td data-bbox="794 1261 954 1294">15 inch-lbs</td> </tr> <tr> <td data-bbox="129 1305 774 1339">Contact Captivation-axial</td> <td data-bbox="794 1305 927 1339">≥ 4.5 lbs</td> </tr> <tr> <td data-bbox="129 1350 774 1384">Durability (mating)</td> <td data-bbox="794 1350 882 1384">≥ 500</td> </tr> </table>		Mechanical Data		Recommended Coupling Nut Torque	7.08 to 9.74 inch lbs	Coupling Proof Torque	15 inch-lbs	Contact Captivation-axial	≥ 4.5 lbs	Durability (mating)	≥ 500								
Mechanical Data																			
Recommended Coupling Nut Torque	7.08 to 9.74 inch lbs																		
Coupling Proof Torque	15 inch-lbs																		
Contact Captivation-axial	≥ 4.5 lbs																		
Durability (mating)	≥ 500																		
<table border="0"> <tr> <td colspan="2" data-bbox="129 1507 531 1556">Environmental Data</td> </tr> <tr> <td data-bbox="129 1563 774 1597">Temperature Range</td> <td data-bbox="794 1563 1034 1597">-55°C to +105°C</td> </tr> <tr> <td data-bbox="129 1608 774 1641">Thermal Shock</td> <td data-bbox="794 1608 1362 1641">MIL-STD-202, Method 107, Condition B</td> </tr> <tr> <td data-bbox="129 1653 774 1686">Moisture Resistance</td> <td data-bbox="794 1653 1177 1686">MIL-STD-202, Method 206</td> </tr> <tr> <td data-bbox="129 1697 774 1731">Corrosion</td> <td data-bbox="794 1697 1362 1731">MIL-STD-202, Method 101, Condition B</td> </tr> <tr> <td data-bbox="129 1742 774 1776">RoHS</td> <td data-bbox="794 1742 946 1776">Compliant</td> </tr> </table>		Environmental Data		Temperature Range	-55°C to +105°C	Thermal Shock	MIL-STD-202, Method 107, Condition B	Moisture Resistance	MIL-STD-202, Method 206	Corrosion	MIL-STD-202, Method 101, Condition B	RoHS	Compliant						
Environmental Data																			
Temperature Range	-55°C to +105°C																		
Thermal Shock	MIL-STD-202, Method 107, Condition B																		
Moisture Resistance	MIL-STD-202, Method 206																		
Corrosion	MIL-STD-202, Method 101, Condition B																		
RoHS	Compliant																		

ADS-18/8-18/8-BFA1.15

