

AD45S-A8A8-27-1.15

45° angle SMA jack to SMA jack
27GHz VSWR 1.15

50Ω

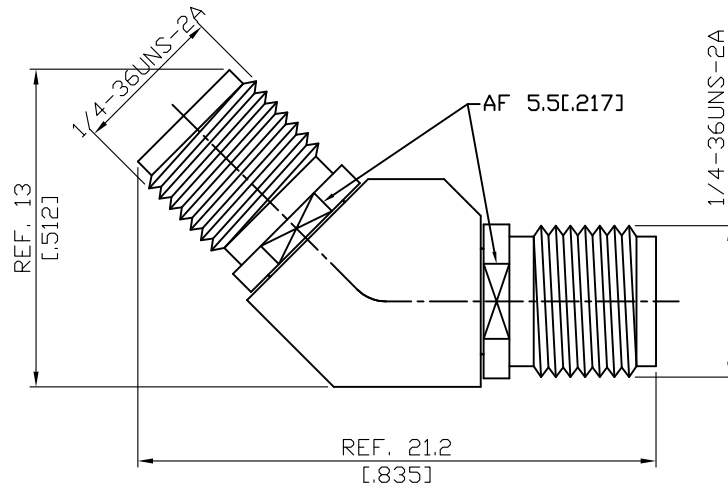

Parts	Material	Plating (Micro-inch)
Body	Stainless Steel	Passivated
Insulator	PTFE	
Contact Pin	Beryllium Copper	Gold 4 Over Nickel-Phosphorus Alloy 80 Over Copper 20

This part number complies with RoHS.

Notice: JYEBAO reserves the right to make modifications deemed appropriate.

AD45S-A8A8-27-1.15	45° angle SMA jack to SMA jack 27GHz VSWR 1.15																
<table border="0"> <tr> <td colspan="2" data-bbox="129 342 531 394">Interface</td> </tr> <tr> <td data-bbox="129 405 794 439">Standard</td> <td data-bbox="794 405 1482 439">MIL-STD-348B</td> </tr> <tr> <td data-bbox="129 450 794 483">Mechanically compatible with</td> <td data-bbox="794 450 1482 483">2.92 & 3.5</td> </tr> </table>		Interface		Standard	MIL-STD-348B	Mechanically compatible with	2.92 & 3.5										
Interface																	
Standard	MIL-STD-348B																
Mechanically compatible with	2.92 & 3.5																
<table border="0"> <tr> <td colspan="2" data-bbox="129 607 531 658">Electrical Data</td> </tr> <tr> <td data-bbox="129 663 794 696">Impedance</td> <td data-bbox="794 663 1482 696">50Ω</td> </tr> <tr> <td data-bbox="129 707 794 741">Frequency Range</td> <td data-bbox="794 707 1482 741">DC To 27GHz</td> </tr> <tr> <td data-bbox="129 752 794 786">VSWR</td> <td data-bbox="794 752 1482 786">≤ 1.15 (DC To 27GHz)</td> </tr> <tr> <td data-bbox="129 797 794 831">Insertion Loss</td> <td data-bbox="794 797 1482 831">≤ 0.06 x √f(GHz) dB</td> </tr> <tr> <td data-bbox="129 842 794 875">Insulation Resistance</td> <td data-bbox="794 842 1482 875">≥ 5000MΩ</td> </tr> <tr> <td data-bbox="129 887 794 920">Dielectric Withstanding Voltage (at sea level)</td> <td data-bbox="794 887 1482 920">1500 V rms</td> </tr> <tr> <td data-bbox="129 931 794 965">Working Voltage (at sea level)</td> <td data-bbox="794 931 1482 965">500 V rms</td> </tr> </table>		Electrical Data		Impedance	50Ω	Frequency Range	DC To 27GHz	VSWR	≤ 1.15 (DC To 27GHz)	Insertion Loss	≤ 0.06 x √f(GHz) dB	Insulation Resistance	≥ 5000MΩ	Dielectric Withstanding Voltage (at sea level)	1500 V rms	Working Voltage (at sea level)	500 V rms
Electrical Data																	
Impedance	50Ω																
Frequency Range	DC To 27GHz																
VSWR	≤ 1.15 (DC To 27GHz)																
Insertion Loss	≤ 0.06 x √f(GHz) dB																
Insulation Resistance	≥ 5000MΩ																
Dielectric Withstanding Voltage (at sea level)	1500 V rms																
Working Voltage (at sea level)	500 V rms																
<table border="0"> <tr> <td colspan="2" data-bbox="129 1106 531 1158">Mechanical Data</td> </tr> <tr> <td data-bbox="129 1162 794 1196">Recommended Coupling Nut Torque</td> <td data-bbox="794 1162 1482 1196">7 to 9.5 in-lbs</td> </tr> <tr> <td data-bbox="129 1207 794 1240">Coupling Proof Torque</td> <td data-bbox="794 1207 1482 1240">15 in-lbs</td> </tr> <tr> <td data-bbox="129 1252 794 1285">Contact Captivation-axial</td> <td data-bbox="794 1252 1482 1285">≥ 6.1 lbs</td> </tr> <tr> <td data-bbox="129 1296 794 1330">Durability (mating)</td> <td data-bbox="794 1296 1482 1330">≥ 500</td> </tr> </table>		Mechanical Data		Recommended Coupling Nut Torque	7 to 9.5 in-lbs	Coupling Proof Torque	15 in-lbs	Contact Captivation-axial	≥ 6.1 lbs	Durability (mating)	≥ 500						
Mechanical Data																	
Recommended Coupling Nut Torque	7 to 9.5 in-lbs																
Coupling Proof Torque	15 in-lbs																
Contact Captivation-axial	≥ 6.1 lbs																
Durability (mating)	≥ 500																
<table border="0"> <tr> <td colspan="2" data-bbox="129 1507 531 1559">Environmental Data</td> </tr> <tr> <td data-bbox="129 1563 794 1597">Temperature Range</td> <td data-bbox="794 1563 1482 1597">-65°C to +165°C</td> </tr> <tr> <td data-bbox="129 1608 794 1641">Thermal Shock</td> <td data-bbox="794 1608 1482 1641">MIL-STD-202, Method 107, Condition B</td> </tr> <tr> <td data-bbox="129 1653 794 1686">Moisture Resistance</td> <td data-bbox="794 1653 1482 1686">MIL-STD-202, Method 206</td> </tr> <tr> <td data-bbox="129 1697 794 1731">Corrosion</td> <td data-bbox="794 1697 1482 1731">MIL-STD-202, Method 101, Condition B</td> </tr> <tr> <td data-bbox="129 1742 794 1776">RoHS</td> <td data-bbox="794 1742 1482 1776">Compliant</td> </tr> </table>		Environmental Data		Temperature Range	-65°C to +165°C	Thermal Shock	MIL-STD-202, Method 107, Condition B	Moisture Resistance	MIL-STD-202, Method 206	Corrosion	MIL-STD-202, Method 101, Condition B	RoHS	Compliant				
Environmental Data																	
Temperature Range	-65°C to +165°C																
Thermal Shock	MIL-STD-202, Method 107, Condition B																
Moisture Resistance	MIL-STD-202, Method 206																
Corrosion	MIL-STD-202, Method 101, Condition B																
RoHS	Compliant																

AD45S-A8A8-27-1.15

