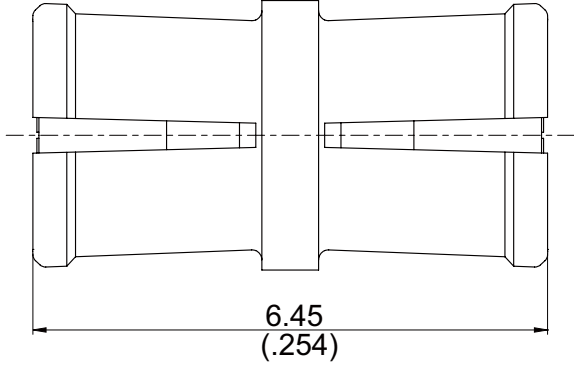

AD-P8P8-6.45	SMP Jack To SMP Jack 18GHz VSWR 1.2		50Ω												
															
<table border="1"> <thead> <tr> <th data-bbox="220 1473 464 1507">Parts</th> <th data-bbox="464 1473 651 1507">Material</th> <th data-bbox="651 1473 1367 1507">Plating (Micro-inch)</th> </tr> </thead> <tbody> <tr> <td data-bbox="220 1507 464 1541">Contact Pin</td> <td data-bbox="464 1507 651 1541">Beryllium Copper</td> <td data-bbox="651 1507 1367 1541">Gold 4 Over Nickel-Phosphorus Alloy 80 Over Copper 20</td> </tr> <tr> <td data-bbox="220 1541 464 1574">Insulator</td> <td data-bbox="464 1541 651 1574">Teflon</td> <td data-bbox="651 1541 1367 1574"></td> </tr> <tr> <td data-bbox="220 1574 464 1608">Body</td> <td data-bbox="464 1574 651 1608">Beryllium Copper</td> <td data-bbox="651 1574 1367 1608">Gold 4 Over Nickel-Phosphorus Alloy 80 Over Copper 20</td> </tr> </tbody> </table>				Parts	Material	Plating (Micro-inch)	Contact Pin	Beryllium Copper	Gold 4 Over Nickel-Phosphorus Alloy 80 Over Copper 20	Insulator	Teflon		Body	Beryllium Copper	Gold 4 Over Nickel-Phosphorus Alloy 80 Over Copper 20
Parts	Material	Plating (Micro-inch)													
Contact Pin	Beryllium Copper	Gold 4 Over Nickel-Phosphorus Alloy 80 Over Copper 20													
Insulator	Teflon														
Body	Beryllium Copper	Gold 4 Over Nickel-Phosphorus Alloy 80 Over Copper 20													

This part number complies with RoHS.

Notice: JYBAO reserves the right to make modifications deemed appropriate.

AD-P8P8-6.45	SMP Jack To SMP Jack 18GHz VSWR 1.2																				
<div style="border: 1px solid black; padding: 2px;">Interface</div> <p>Standard</p>	MIL-STD-348B																				
<div style="border: 1px solid black; padding: 2px;">Electrical Data</div> <p>Impedance</p> <p>Frequency Range</p> <p>VSWR</p> <p>Insertion Loss</p> <p>Insulation Resistance</p> <p>Dielectric Withstanding Voltage (at sea level)</p> <p>Working Voltage (at sea level)</p>	<p>50Ω</p> <p>DC To 18GHz</p> <p>≤ 1.2 (DC To 18GHz)</p> <p>≤ 0.06 x √f(GHz) dB</p> <p>≥ 5000MΩ</p> <p>500 V rms</p> <p>335 V rms</p>																				
<div style="border: 1px solid black; padding: 2px;">Mechanical Data</div> <p>Durability (mating)</p> <p>Engagement Force</p> <p>Disengagement Force</p> <p>Axial Misalignment</p> <p>Radial Misalignment</p>	<table border="1" style="width: 100%; border-collapse: collapse; text-align: center;"> <thead> <tr> <th style="border: none;">Full detent</th> <th style="border: none;">Limited detent</th> <th style="border: none;">Smooth bore Catchers Mit</th> </tr> </thead> <tbody> <tr> <td style="border: none;">≥ 100</td> <td style="border: none;">≥ 500</td> <td style="border: none;">≥ 1000</td> </tr> <tr> <td style="border: none;">≤ 15 lbs</td> <td style="border: none;">≤ 10 lbs</td> <td style="border: none;">≤ 2 lbs</td> </tr> <tr> <td style="border: none;">≥ 5 lbs</td> <td style="border: none;">≥ 2 lbs</td> <td style="border: none;">≥ 0.5 lbs</td> </tr> <tr> <td colspan="3" style="border: none;">+0.00/-0.25(+.000/-0.010)</td> </tr> <tr> <td colspan="3" style="border: none;">+/-0.25(0.010)</td> </tr> </tbody> </table>			Full detent	Limited detent	Smooth bore Catchers Mit	≥ 100	≥ 500	≥ 1000	≤ 15 lbs	≤ 10 lbs	≤ 2 lbs	≥ 5 lbs	≥ 2 lbs	≥ 0.5 lbs	+0.00/-0.25(+.000/-0.010)			+/-0.25(0.010)		
Full detent	Limited detent	Smooth bore Catchers Mit																			
≥ 100	≥ 500	≥ 1000																			
≤ 15 lbs	≤ 10 lbs	≤ 2 lbs																			
≥ 5 lbs	≥ 2 lbs	≥ 0.5 lbs																			
+0.00/-0.25(+.000/-0.010)																					
+/-0.25(0.010)																					
<div style="border: 1px solid black; padding: 2px;">Environmental Data</div> <p>Temperature Range</p> <p>Thermal Shock</p> <p>Moisture Resistance</p> <p>Corrosion</p> <p>RoHS</p>	<p>-65°C to +165°C</p> <p>MIL-STD-202, Method 107, Condition B</p> <p>MIL-STD-202, Method 206</p> <p>MIL-STD-202, Method 101, Condition B</p> <p>Compliant</p>																				

Notice: JYEBAO reserves the right to make modifications deemed appropriate.

SoftPlot Measurement Presentation
VSWR S11

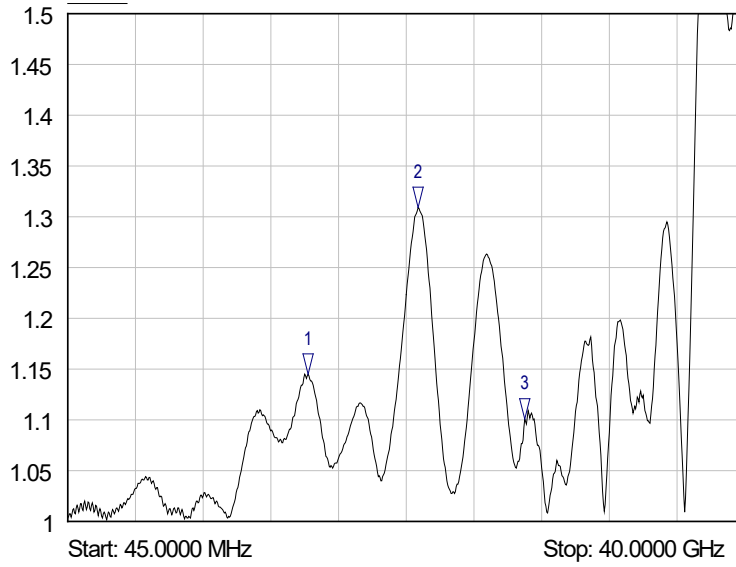

- 1 S11
▽ 14.2290 GHz
1.15 VSWR
- 2 S11
▽ 20.7217 GHz
1.31 VSWR
- 3 S11
▽ 27.0146 GHz
1.10 VSWR