

AD-N8DI8/LP	Low PIM N Jack to 7/16 Jack 7.5GHz VSWR 1.15	50Ω
-------------	---	-----

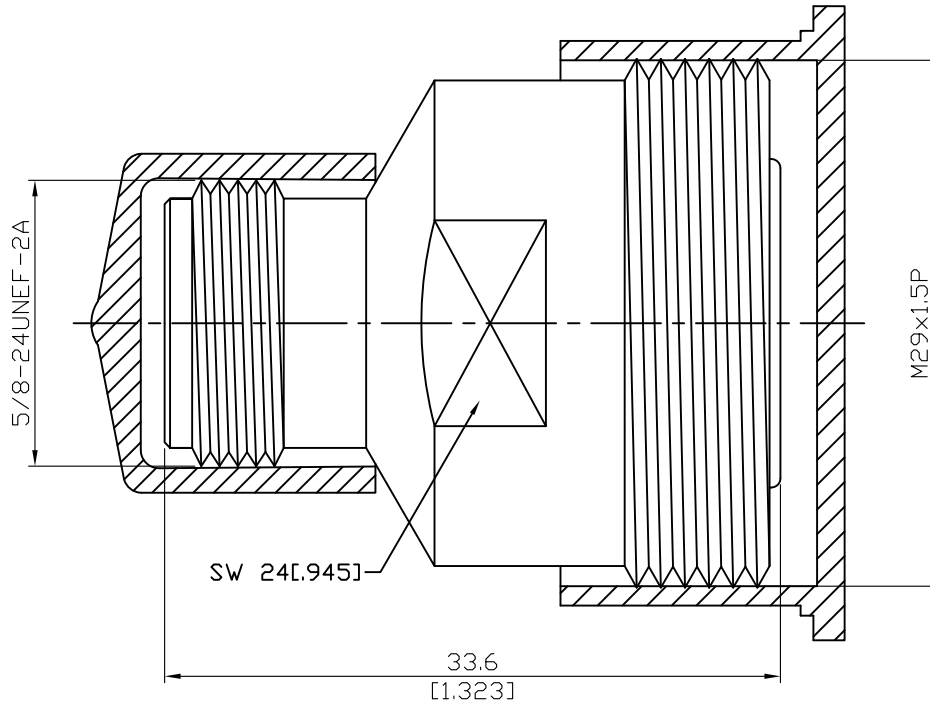

Intermodulation:  $\geq 165$  dBC

Parts	Material	Plating ( Micro-inch )
Cover	PE (Black)	
Cover	PVC (Black)	
Contact Pin	Phosphor Bronze	Gold 4 Over Nickel-Phosphorus Alloy 80 Over Copper 20
Insulator	Teflon	
Body	Brass	Tin-Zinc-Copper-Alloy 100 Over Copper 50

--	--

This part number complies with RoHS.

Notice: JYEBAO reserves the right to make modifications deemed appropriate.

AD-N8DI8/LP	Low PIM N Jack to 7/16 Jack 7.5GHz VSWR 1.15											
<b>Interface</b> Standard	<table border="1"> <thead> <tr> <th data-bbox="783 344 1123 394">7/16</th> <th data-bbox="1123 344 1481 394">N</th> </tr> </thead> <tbody> <tr> <td data-bbox="783 394 1123 443">IEC 60169-4</td> <td data-bbox="1123 394 1481 443">MIL-STD-348B</td> </tr> </tbody> </table>	7/16	N	IEC 60169-4	MIL-STD-348B							
7/16	N											
IEC 60169-4	MIL-STD-348B											
<b>Electrical Data</b> Impedance Frequency Range VSWR Insertion Loss Insulation Resistance Dielectric Withstanding Voltage (at sea level) Working Voltage (at sea level)	<table> <tbody> <tr> <td>50Ω</td> </tr> <tr> <td>DC To 7.5GHz</td> </tr> <tr> <td>≤ 1.15 (DC To 7.5GHz)</td> </tr> <tr> <td>≤ 0.04 x √f(GHz) dB</td> </tr> <tr> <td>≥ 5000MΩ</td> </tr> <tr> <td>2500 V rms</td> </tr> <tr> <td>1000 V rms</td> </tr> </tbody> </table>		50Ω	DC To 7.5GHz	≤ 1.15 (DC To 7.5GHz)	≤ 0.04 x √f(GHz) dB	≥ 5000MΩ	2500 V rms	1000 V rms			
50Ω												
DC To 7.5GHz												
≤ 1.15 (DC To 7.5GHz)												
≤ 0.04 x √f(GHz) dB												
≥ 5000MΩ												
2500 V rms												
1000 V rms												
<b>Mechanical Data</b> Recommended Coupling Nut Torque Coupling Proof Torque Contact Captivation-axial Durability (mating)	<table border="1"> <thead> <tr> <th data-bbox="783 1059 1123 1108">7/16</th> <th data-bbox="1123 1059 1481 1108">N</th> </tr> </thead> <tbody> <tr> <td data-bbox="783 1108 1123 1158">260 in-lbs</td> <td data-bbox="1123 1108 1481 1158">6 to 10 in-lbs</td> </tr> <tr> <td data-bbox="783 1158 1123 1207">310 in-lbs</td> <td data-bbox="1123 1158 1481 1207">15 in-lbs</td> </tr> <tr> <td data-bbox="783 1207 1123 1256">≥ 45 lbs</td> <td data-bbox="1123 1207 1481 1256">≥ 6.3 lbs</td> </tr> <tr> <td data-bbox="783 1256 1123 1305">≥ 500</td> <td data-bbox="1123 1256 1481 1305">≥ 500</td> </tr> </tbody> </table>		7/16	N	260 in-lbs	6 to 10 in-lbs	310 in-lbs	15 in-lbs	≥ 45 lbs	≥ 6.3 lbs	≥ 500	≥ 500
7/16	N											
260 in-lbs	6 to 10 in-lbs											
310 in-lbs	15 in-lbs											
≥ 45 lbs	≥ 6.3 lbs											
≥ 500	≥ 500											
<b>Environmental Data</b> Temperature Range Thermal Shock Moisture Resistance Corrosion RoHS	<table> <tbody> <tr> <td>-65°C to +165°C</td> </tr> <tr> <td>MIL-STD-202, Method 107, Condition B</td> </tr> <tr> <td>MIL-STD-202, Method 206</td> </tr> <tr> <td>MIL-STD-202, Method 101, Condition B</td> </tr> <tr> <td>Compliant</td> </tr> </tbody> </table>		-65°C to +165°C	MIL-STD-202, Method 107, Condition B	MIL-STD-202, Method 206	MIL-STD-202, Method 101, Condition B	Compliant					
-65°C to +165°C												
MIL-STD-202, Method 107, Condition B												
MIL-STD-202, Method 206												
MIL-STD-202, Method 101, Condition B												
Compliant												

# AD-N8DI8/LP

SoftPlot Measurement Presentation  
VSWR S22

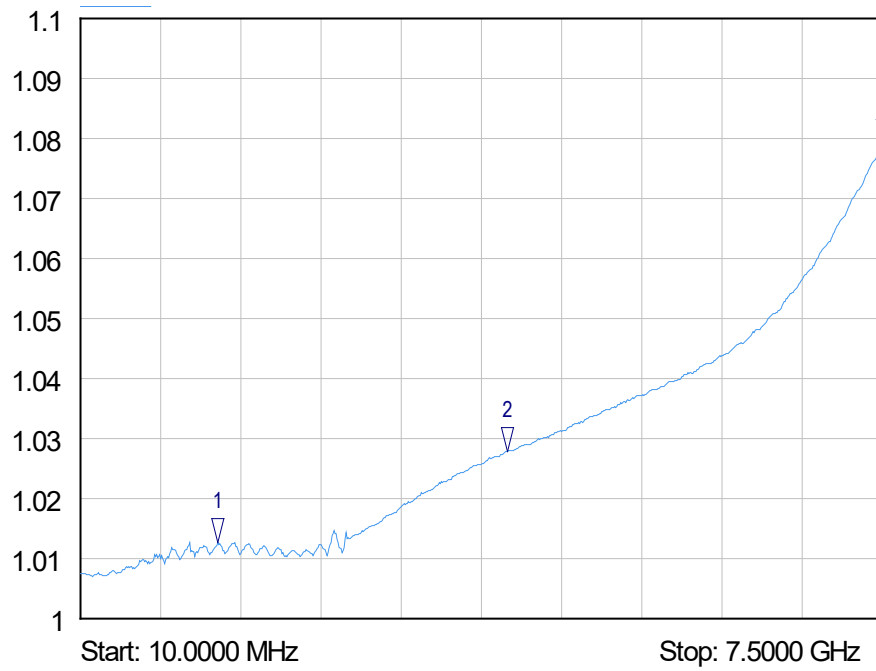

- 1 S22  
▽ 1.2900 GHz  
1.01 VSWR
- 2 S22  
▽ 4.0000 GHz  
1.03 VSWR
- 3 S22  
▽ 7.5000 GHz  
1.08 VSWR