

AD-N8DI3/LP	Low PIM N Jack to 7/16 Plug 7.5GHz VSWR 1.15	50Ω
-------------	---	-----

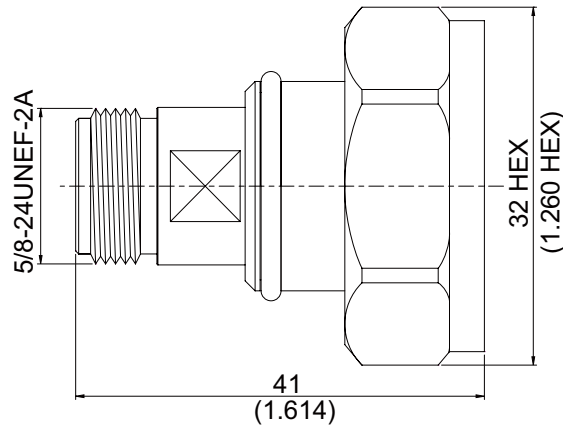

NOTE: Intermodulation: ≥165 dBC

Parts	Material	Plating (Micro-inch)
Gasket	Silicon	
Contact Pin	Phosphor Bronze	Gold 4 Over Nickel-Phosphorus Alloy 80 Over Copper 20
Insulator	Teflon	
Body	Brass	Tin-Zinc-Copper-Alloy 100 Over Copper 50
Coupling Nut	Brass	Tin-Zinc-Copper-Alloy 100 Over Copper 50

Weight:

This part number complies with RoHS.

Notice: JYEBAO reserves the right to make modifications deemed appropriate.

AD-N8DI3/LP	Low PIM N Jack to 7/16 Plug 7.5GHz VSWR 1.15	
<div style="border: 1px solid black; padding: 2px; margin-bottom: 5px;">Interface</div> Standard	7/16 IEC 60169-4	N MIL-STD-348B
<div style="border: 1px solid black; padding: 2px; margin-bottom: 5px;">Electrical Data</div> Impedance Frequency Range VSWR Insertion Loss Insulation Resistance Dielectric Withstanding Voltage (at sea level) Working Voltage (at sea level)	50Ω DC To 7.5GHz ≤ 1.15 (DC To 7.5GHz) ≤ 0.04 x √f(GHz) dB ≥ 5000MΩ 2500 V rms 1000 V rms	
<div style="border: 1px solid black; padding: 2px; margin-bottom: 5px;">Mechanical Data</div> Recommended Coupling Nut Torque Coupling Proof Torque Coupling Nut Retention Force Contact Captivation-axial Durability (mating)	7/16 260 in-lbs 310 in-lbs ≥ 221 lbs ≥ 45 lbs ≥ 500	N 6 to 10 in-lbs 15 in-lbs NA ≥ 6.3 lbs ≥ 500
<div style="border: 1px solid black; padding: 2px; margin-bottom: 5px;">Environmental Data</div> Temperature Range Thermal Shock Moisture Resistance Corrosion RoHS	-65°C to +165°C MIL-STD-202, Method 107, Condition B MIL-STD-202, Method 206 MIL-STD-202, Method 101, Condition B Compliant	

AD-N8DI3/LP

SoftPlot Measurement Presentation
VSWR S22

