

AD-N8CQ3-P4	N Jack to Snap On C Plug 4 Hole Flange 8GHz VSWR 1.2	50Ω
-------------	---	-----

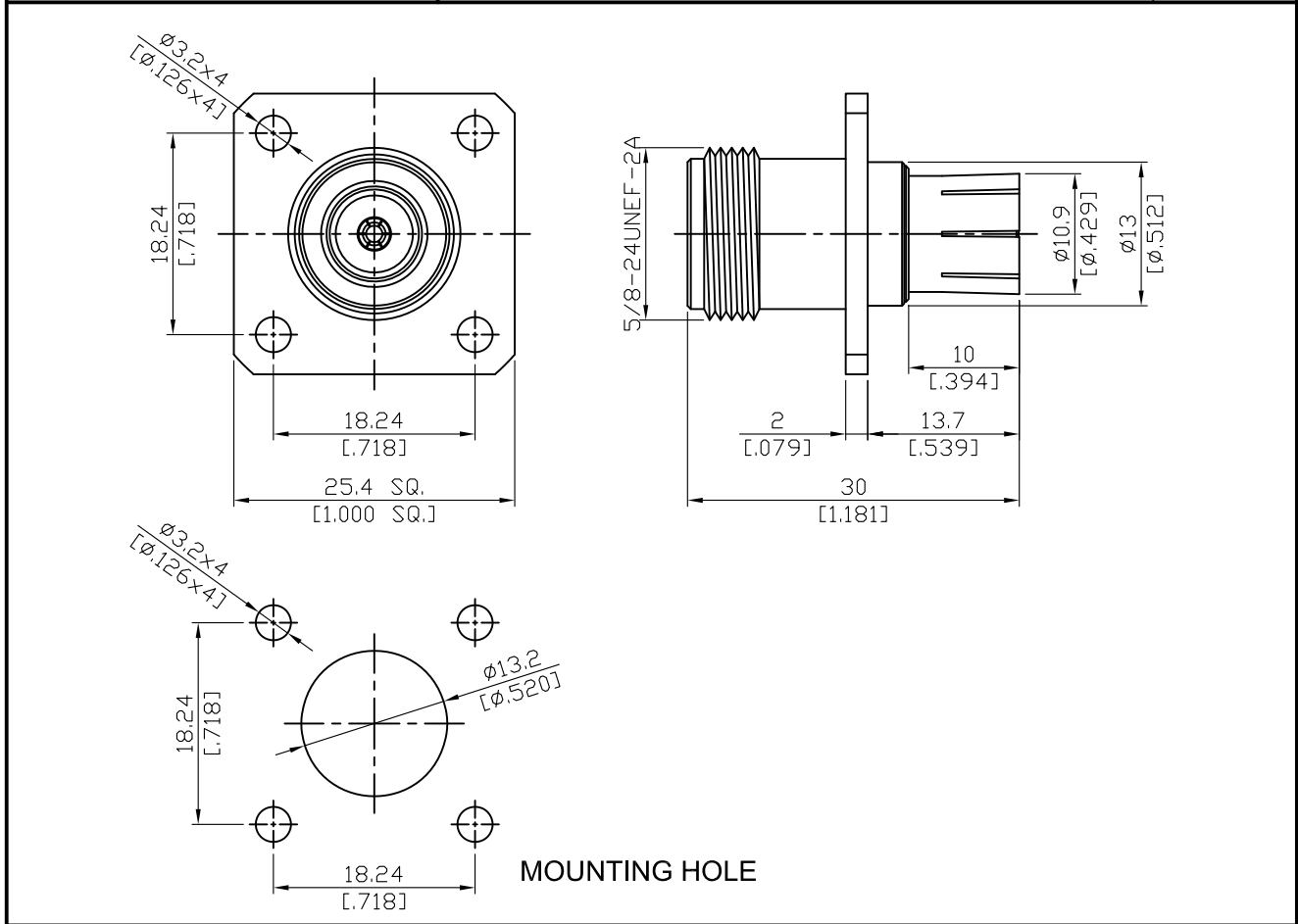

Parts	Material	Plating ( Micro-inch )
Body	Brass	Tin-Zinc-Copper-Alloy 100 Over Copper 50
Insulator	Teflon	
Contact Pin	Beryllium Copper	Gold 4 Over Nickel-Phosphorus Alloy 80 Over Copper 20

--	--

This part number complies with RoHS.

Notice: JYEBAO reserves the right to make modifications deemed appropriate.

AD-N8CQ3-P4	N Jack To Snap On C Plug 4 Hole Flange 8GHz VSWR 1.2																									
Interface	N Jack Screw Side	C Plug Snap On Side																								
Standard	MIL-STD-348B	Per JYEBAO Snap On C Plug																								
<table border="0" style="width: 100%;"> <tr> <td style="border: 1px solid black;">Electrical Data</td> <td></td> <td></td> </tr> <tr> <td>Impedance</td> <td>50Ω</td> <td></td> </tr> <tr> <td>Frequency Range</td> <td>DC To 8GHz</td> <td></td> </tr> <tr> <td>VSWR</td> <td>≤ 1.2 (DC To 8GHz)</td> <td></td> </tr> <tr> <td>Insertion Loss</td> <td>≤ 0.06 x √f(GHz) dB</td> <td></td> </tr> <tr> <td>Insulation Resistance</td> <td>≥ 5000MΩ</td> <td></td> </tr> <tr> <td>Dielectric Withstanding Voltage (at sea level)</td> <td>2500 V rms</td> <td></td> </tr> <tr> <td>Working Voltage (at sea level)</td> <td>1000 V rms</td> <td></td> </tr> </table>			Electrical Data			Impedance	50Ω		Frequency Range	DC To 8GHz		VSWR	≤ 1.2 (DC To 8GHz)		Insertion Loss	≤ 0.06 x √f(GHz) dB		Insulation Resistance	≥ 5000MΩ		Dielectric Withstanding Voltage (at sea level)	2500 V rms		Working Voltage (at sea level)	1000 V rms	
Electrical Data																										
Impedance	50Ω																									
Frequency Range	DC To 8GHz																									
VSWR	≤ 1.2 (DC To 8GHz)																									
Insertion Loss	≤ 0.06 x √f(GHz) dB																									
Insulation Resistance	≥ 5000MΩ																									
Dielectric Withstanding Voltage (at sea level)	2500 V rms																									
Working Voltage (at sea level)	1000 V rms																									
<table border="0" style="width: 100%;"> <tr> <td style="border: 1px solid black;">Mechanical Data</td> <td></td> <td></td> </tr> <tr> <td></td> <td style="text-align: center;">N</td> <td style="text-align: center;">C</td> </tr> <tr> <td>Recommended Coupling Nut Torque</td> <td style="text-align: center;">6 to 10 in-lbs</td> <td style="text-align: center;">NA(Snap On)</td> </tr> <tr> <td>Coupling Proof Torque</td> <td style="text-align: center;">15 in-lbs</td> <td style="text-align: center;">NA(Snap On)</td> </tr> <tr> <td>Contact Captivation-axial</td> <td style="text-align: center;">≥ 6.3 lbs</td> <td style="text-align: center;">≥ 6 lbs</td> </tr> <tr> <td>Durability (mating)</td> <td style="text-align: center;">≥ 500</td> <td style="text-align: center;">≥ 500</td> </tr> </table>			Mechanical Data				N	C	Recommended Coupling Nut Torque	6 to 10 in-lbs	NA(Snap On)	Coupling Proof Torque	15 in-lbs	NA(Snap On)	Contact Captivation-axial	≥ 6.3 lbs	≥ 6 lbs	Durability (mating)	≥ 500	≥ 500						
Mechanical Data																										
	N	C																								
Recommended Coupling Nut Torque	6 to 10 in-lbs	NA(Snap On)																								
Coupling Proof Torque	15 in-lbs	NA(Snap On)																								
Contact Captivation-axial	≥ 6.3 lbs	≥ 6 lbs																								
Durability (mating)	≥ 500	≥ 500																								
<table border="0" style="width: 100%;"> <tr> <td style="border: 1px solid black;">Environmental Data</td> <td></td> <td></td> </tr> <tr> <td>Temperature Range</td> <td colspan="2" style="text-align: center;">-65°C to +165°C</td> </tr> <tr> <td>Thermal Shock</td> <td colspan="2" style="text-align: center;">MIL-STD-202, Method 107, Condition B</td> </tr> <tr> <td>Moisture Resistance</td> <td colspan="2" style="text-align: center;">MIL-STD-202, Method 206</td> </tr> <tr> <td>Corrosion</td> <td colspan="2" style="text-align: center;">MIL-STD-202, Method 101, Condition B</td> </tr> <tr> <td>RoHS</td> <td colspan="2" style="text-align: center;">Compliant</td> </tr> </table>			Environmental Data			Temperature Range	-65°C to +165°C		Thermal Shock	MIL-STD-202, Method 107, Condition B		Moisture Resistance	MIL-STD-202, Method 206		Corrosion	MIL-STD-202, Method 101, Condition B		RoHS	Compliant							
Environmental Data																										
Temperature Range	-65°C to +165°C																									
Thermal Shock	MIL-STD-202, Method 107, Condition B																									
Moisture Resistance	MIL-STD-202, Method 206																									
Corrosion	MIL-STD-202, Method 101, Condition B																									
RoHS	Compliant																									

Notice: JYEBAO reserves the right to make modifications deemed appropriate.

# AD-N8CQ3-P4

