

AD-N8B3

N Jack To BNC Plug  
11GHz VSWR 1.25

50Ω

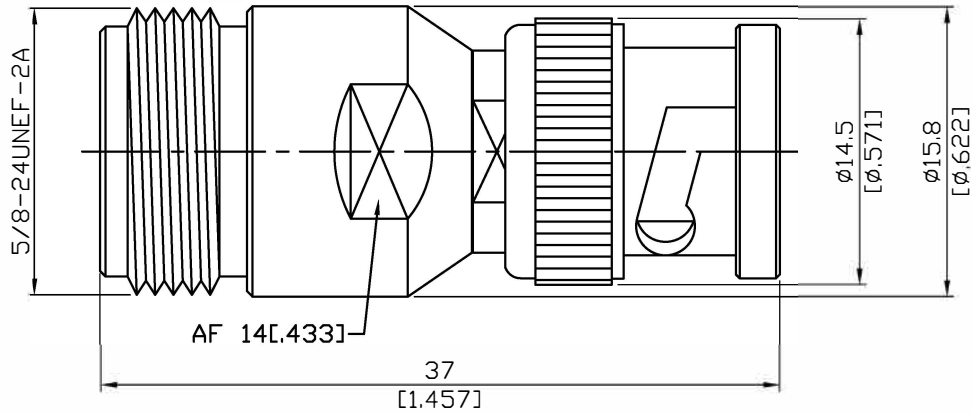

Parts	Material	Plating ( Micro-inch )
Contact Pin	Beryllium Copper	Gold 4 Over Nickel-Phosphorus Alloy 80 Over Copper 20
Insulator	Teflon	
Body	Brass	Tin-Zinc-Copper-Alloy 100 Over Copper 50
Washer	Brass	Tin-Zinc-Copper-Alloy 100 Over Copper 50
Gasket	Silicon	
Coupling Nut	Brass	Tin-Zinc-Copper-Alloy 100 Over Copper 50
Spring	SK5	Tin-Zinc-Copper-Alloy 100 Over Copper 50

This part number complies with RoHS.

Notice: JYEBAO reserves the right to make modifications deemed appropriate.

AD-N8B3	N Jack To BNC Plug 11GHz VSWR 1.25																			
<div style="border: 1px solid black; padding: 2px; margin-bottom: 5px;">Interface</div> Standard	<table border="1" style="width: 100%; border-collapse: collapse;"> <thead> <tr> <th style="width: 50%; text-align: center;">N</th> <th style="width: 50%; text-align: center;">BNC</th> </tr> </thead> <tbody> <tr> <td style="text-align: center;">MIL-STD-348B</td> <td style="text-align: center;">MIL-STD-348B</td> </tr> </tbody> </table>	N	BNC	MIL-STD-348B	MIL-STD-348B															
N	BNC																			
MIL-STD-348B	MIL-STD-348B																			
<div style="border: 1px solid black; padding: 2px; margin-bottom: 5px;">Electrical Data</div> Impedance Frequency Range VSWR Insertion Loss Insulation Resistance Dielectric Withstanding Voltage (at sea level) Working Voltage (at sea level)	<table style="width: 100%; border-collapse: collapse;"> <tbody> <tr> <td style="width: 50%;"></td> <td style="width: 50%; text-align: center;">50Ω</td> </tr> <tr> <td></td> <td style="text-align: center;">DC To 11GHz</td> </tr> <tr> <td></td> <td style="text-align: center;">≤ 1.25 (DC To 11GHz)</td> </tr> <tr> <td></td> <td style="text-align: center;">≤ 0.06 x √f(GHz) dB</td> </tr> <tr> <td></td> <td style="text-align: center;">≥ 5000MΩ</td> </tr> <tr> <td></td> <td style="text-align: center;">1500 V rms</td> </tr> <tr> <td></td> <td style="text-align: center;">500 V rms</td> </tr> </tbody> </table>			50Ω		DC To 11GHz		≤ 1.25 (DC To 11GHz)		≤ 0.06 x √f(GHz) dB		≥ 5000MΩ		1500 V rms		500 V rms				
	50Ω																			
	DC To 11GHz																			
	≤ 1.25 (DC To 11GHz)																			
	≤ 0.06 x √f(GHz) dB																			
	≥ 5000MΩ																			
	1500 V rms																			
	500 V rms																			
<div style="border: 1px solid black; padding: 2px; margin-bottom: 5px;">Mechanical Data</div> Recommended Coupling Nut Torque Coupling Proof Torque Coupling Nut Retention Force Contact Captivation-axial Durability (mating)	<table border="1" style="width: 100%; border-collapse: collapse;"> <thead> <tr> <th style="width: 50%;"></th> <th style="width: 25%; text-align: center;">N</th> <th style="width: 25%; text-align: center;">BNC</th> </tr> </thead> <tbody> <tr> <td style="width: 50%;">Recommended Coupling Nut Torque</td> <td style="text-align: center;">6 to 10 in-lbs</td> <td style="text-align: center;">0.6 to 2.5 in-lbs</td> </tr> <tr> <td>Coupling Proof Torque</td> <td style="text-align: center;">15 in-lbs</td> <td style="text-align: center;">NA</td> </tr> <tr> <td>Coupling Nut Retention Force</td> <td style="text-align: center;">NA</td> <td style="text-align: center;">≥ 101.2 lbs</td> </tr> <tr> <td>Contact Captivation-axial</td> <td style="text-align: center;">≥ 6.3 lbs</td> <td style="text-align: center;">≥ 6.1 lbs</td> </tr> <tr> <td>Durability (mating)</td> <td style="text-align: center;">≥ 500</td> <td style="text-align: center;">≥ 500</td> </tr> </tbody> </table>			N	BNC	Recommended Coupling Nut Torque	6 to 10 in-lbs	0.6 to 2.5 in-lbs	Coupling Proof Torque	15 in-lbs	NA	Coupling Nut Retention Force	NA	≥ 101.2 lbs	Contact Captivation-axial	≥ 6.3 lbs	≥ 6.1 lbs	Durability (mating)	≥ 500	≥ 500
	N	BNC																		
Recommended Coupling Nut Torque	6 to 10 in-lbs	0.6 to 2.5 in-lbs																		
Coupling Proof Torque	15 in-lbs	NA																		
Coupling Nut Retention Force	NA	≥ 101.2 lbs																		
Contact Captivation-axial	≥ 6.3 lbs	≥ 6.1 lbs																		
Durability (mating)	≥ 500	≥ 500																		
<div style="border: 1px solid black; padding: 2px; margin-bottom: 5px;">Environmental Data</div> Temperature Range Thermal Shock Moisture Resistance Corrosion RoHS	<table style="width: 100%; border-collapse: collapse;"> <tbody> <tr> <td style="width: 50%;"></td> <td style="width: 50%; text-align: center;">-65°C to +165°C</td> </tr> <tr> <td></td> <td style="text-align: center;">MIL-STD-202, Method 107, Condition B</td> </tr> <tr> <td></td> <td style="text-align: center;">MIL-STD-202, Method 206</td> </tr> <tr> <td></td> <td style="text-align: center;">MIL-STD-202, Method 101, Condition B</td> </tr> <tr> <td></td> <td style="text-align: center;">Compliant</td> </tr> </tbody> </table>			-65°C to +165°C		MIL-STD-202, Method 107, Condition B		MIL-STD-202, Method 206		MIL-STD-202, Method 101, Condition B		Compliant								
	-65°C to +165°C																			
	MIL-STD-202, Method 107, Condition B																			
	MIL-STD-202, Method 206																			
	MIL-STD-202, Method 101, Condition B																			
	Compliant																			

Notice: JYEBAO reserves the right to make modifications deemed appropriate.

# AD-N8B3

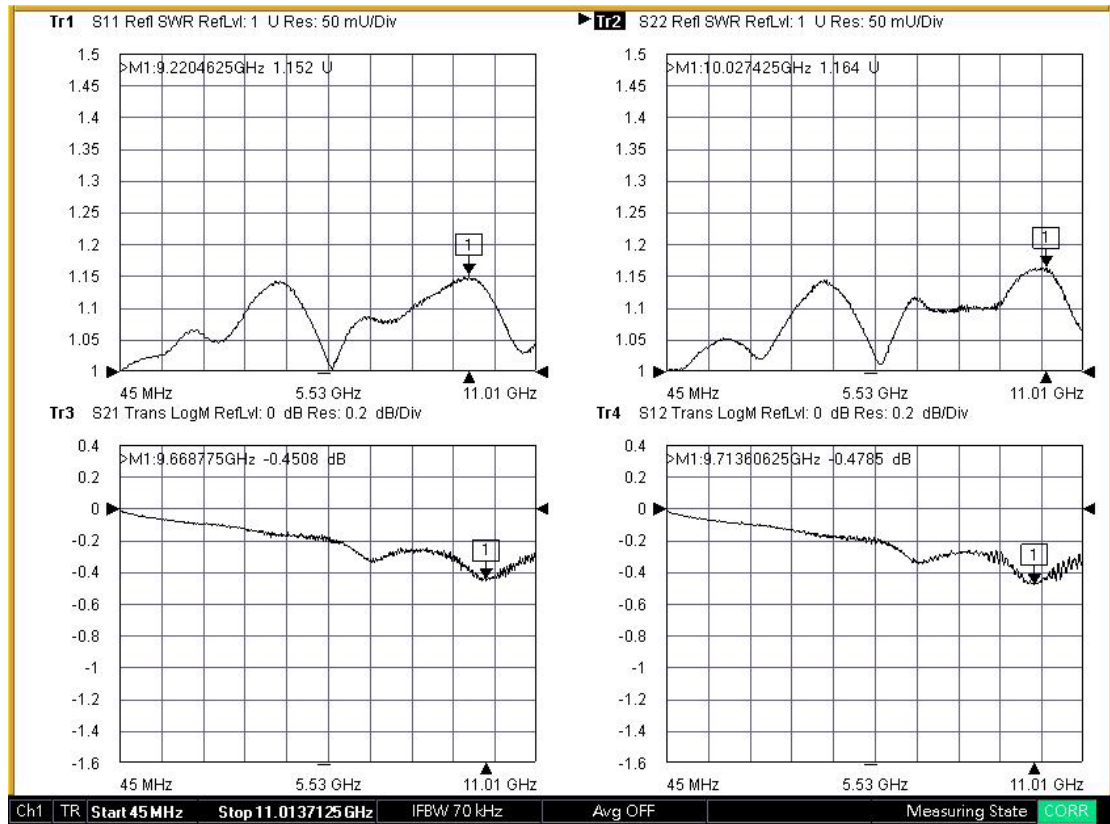

Note: S11/S12/S21/S22 plots shown represent IL and VSWR of two adaptors tested. To extract IL of a single adaptor divide IL measured by two.