

AD-N3B9

N Plug To BNC Reverse Polarity Jack  
4GHz VSWR 1.2

50Ω

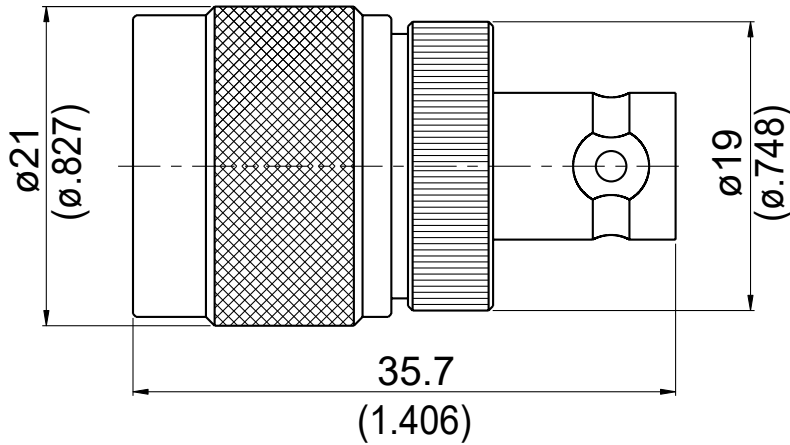

Parts	Material	Plating (Micro-inch)
Insulator	Teflon	
Body	Brass	Tin-Zinc-Copper-Alloy 100 Over Copper 50
Contact Body	Brass	Tin-Zinc-Copper-Alloy 100 Over Copper 50
Retainer Ring	Brass	Tin-Zinc-Copper-Alloy 100 Over Copper 50
Gasket	Silicon	
Coupling Nut(N)	Brass	Tin-Zinc-Copper-Alloy 100 Over Copper 50
Contact Pin	Brass	Gold 4 Over Nickel-Phosphorus Alloy 80 Over Copper 20

Weight: 40.2 g

This part number complies with RoHS.

Notice: JYEBAO reserves the right to make modifications deemed appropriate.

AD-N3B9	N Plug To BNC Reverse Polarity Jack 4GHz VSWR 1.2																						
<div style="border: 1px solid black; padding: 2px; margin-bottom: 5px;">Interface</div> <p>Standard Polarity N Plug Side: Per MIL-STD-348B</p> <p>Reverse Polarity BNC Jack Side: Per JYEBAO BNC Reverse Polarity Jack derived from MIL-STD-348B</p>																							
<div style="border: 1px solid black; padding: 2px; margin-bottom: 5px;">Electrical Data</div> <table style="width: 100%; border-collapse: collapse;"> <tr> <td style="width: 50%;">Impedance</td> <td colspan="2" style="text-align: right;">50Ω</td> </tr> <tr> <td>Frequency Range</td> <td colspan="2" style="text-align: right;">DC To 4GHz</td> </tr> <tr> <td>VSWR</td> <td colspan="2" style="text-align: right;">≤ 1.2 (DC To 4GHz)</td> </tr> <tr> <td>Insertion Loss</td> <td colspan="2" style="text-align: right;">≤ 0.06 x √f(GHz) dB</td> </tr> <tr> <td>Insulation Resistance</td> <td colspan="2" style="text-align: right;">≥ 5000MΩ</td> </tr> <tr> <td>Dielectric Withstanding Voltage (at sea level)</td> <td colspan="2" style="text-align: right;">1500 V rms</td> </tr> <tr> <td>Working Voltage (at sea level)</td> <td colspan="2" style="text-align: right;">500 V rms</td> </tr> </table>			Impedance	50Ω		Frequency Range	DC To 4GHz		VSWR	≤ 1.2 (DC To 4GHz)		Insertion Loss	≤ 0.06 x √f(GHz) dB		Insulation Resistance	≥ 5000MΩ		Dielectric Withstanding Voltage (at sea level)	1500 V rms		Working Voltage (at sea level)	500 V rms	
Impedance	50Ω																						
Frequency Range	DC To 4GHz																						
VSWR	≤ 1.2 (DC To 4GHz)																						
Insertion Loss	≤ 0.06 x √f(GHz) dB																						
Insulation Resistance	≥ 5000MΩ																						
Dielectric Withstanding Voltage (at sea level)	1500 V rms																						
Working Voltage (at sea level)	500 V rms																						
<div style="border: 1px solid black; padding: 2px; margin-bottom: 5px;">Mechanical Data</div> <table style="width: 100%; border-collapse: collapse;"> <thead> <tr> <th style="width: 50%;"></th> <th style="width: 25%; text-align: center;">N</th> <th style="width: 25%; text-align: center;">BNC</th> </tr> </thead> <tbody> <tr> <td>Recommended Coupling Nut Torque</td> <td style="text-align: center;">6 to 10 in-lbs</td> <td style="text-align: center;">0.6 to 2.5 in-lbs</td> </tr> <tr> <td>Coupling Proof Torque</td> <td style="text-align: center;">15 in-lbs</td> <td style="text-align: center;">NA</td> </tr> <tr> <td>Coupling Nut Retention Force</td> <td style="text-align: center;">≥ 101.2 lbs</td> <td style="text-align: center;">NA</td> </tr> <tr> <td>Contact Captivation-axial</td> <td style="text-align: center;">≥ 6.3 lbs</td> <td style="text-align: center;">≥ 6.1 lbs</td> </tr> <tr> <td>Durability (mating)</td> <td style="text-align: center;">≥ 500</td> <td style="text-align: center;">≥ 500</td> </tr> </tbody> </table>				N	BNC	Recommended Coupling Nut Torque	6 to 10 in-lbs	0.6 to 2.5 in-lbs	Coupling Proof Torque	15 in-lbs	NA	Coupling Nut Retention Force	≥ 101.2 lbs	NA	Contact Captivation-axial	≥ 6.3 lbs	≥ 6.1 lbs	Durability (mating)	≥ 500	≥ 500			
	N	BNC																					
Recommended Coupling Nut Torque	6 to 10 in-lbs	0.6 to 2.5 in-lbs																					
Coupling Proof Torque	15 in-lbs	NA																					
Coupling Nut Retention Force	≥ 101.2 lbs	NA																					
Contact Captivation-axial	≥ 6.3 lbs	≥ 6.1 lbs																					
Durability (mating)	≥ 500	≥ 500																					
<div style="border: 1px solid black; padding: 2px; margin-bottom: 5px;">Environmental Data</div> <table style="width: 100%; border-collapse: collapse;"> <tr> <td style="width: 50%;">Temperature Range</td> <td colspan="2" style="text-align: right;">-65°C to +165°C</td> </tr> <tr> <td>Thermal Shock</td> <td colspan="2" style="text-align: right;">MIL-STD-202, Method 107, Condition B</td> </tr> <tr> <td>Moisture Resistance</td> <td colspan="2" style="text-align: right;">MIL-STD-202, Method 206</td> </tr> <tr> <td>Corrosion</td> <td colspan="2" style="text-align: right;">MIL-STD-202, Method 101, Condition B</td> </tr> <tr> <td>RoHS</td> <td colspan="2" style="text-align: right;">Compliant</td> </tr> </table>			Temperature Range	-65°C to +165°C		Thermal Shock	MIL-STD-202, Method 107, Condition B		Moisture Resistance	MIL-STD-202, Method 206		Corrosion	MIL-STD-202, Method 101, Condition B		RoHS	Compliant							
Temperature Range	-65°C to +165°C																						
Thermal Shock	MIL-STD-202, Method 107, Condition B																						
Moisture Resistance	MIL-STD-202, Method 206																						
Corrosion	MIL-STD-202, Method 101, Condition B																						
RoHS	Compliant																						

Notice: JYEBAO reserves the right to make modifications deemed appropriate.