

AD-F3F8	F Plug to F Jack 4GHz VSWR 1.25	75Ω
---------	------------------------------------	-----

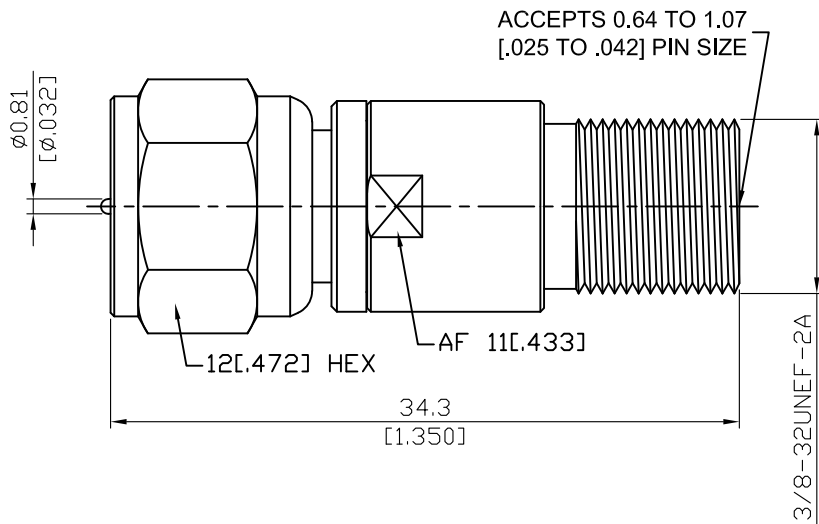

Parts	Material	Plating (Micro-inch)
Contact Body	Brass	Tin-Zinc-Copper-Alloy 100 Over Copper 50
Retainer Ring	Brass	Tin-Zinc-Copper-Alloy 100 Over Copper 50
Contact Pin	Beryllium Copper	Gold 4 Over Nickel-Phosphorus Alloy 80 Over Copper 20
Insulator	Teflon & PE	
Coupling Nut	Brass	Tin-Zinc-Copper-Alloy 100 Over Copper 50
Body	Brass	Tin-Zinc-Copper-Alloy 100 Over Copper 50

--	--

This part number complies with RoHS.

Notice: JYEBAO reserves the right to make modifications deemed appropriate.

AD-F3F8	F Plug to F Jack 4GHz VSWR 1.25														
<table border="1" style="width: 100%; border-collapse: collapse;"> <tr> <td style="width: 30%; padding: 5px;">Interface</td> <td></td> </tr> <tr> <td style="padding: 5px;">Standard</td> <td style="text-align: center; padding: 5px;">IEC 61169-24</td> </tr> </table>		Interface		Standard	IEC 61169-24										
Interface															
Standard	IEC 61169-24														
<table border="1" style="width: 100%; border-collapse: collapse;"> <tr> <td style="width: 30%; padding: 5px;">Electrical Data</td> <td></td> </tr> <tr> <td style="padding: 5px;">Impedance</td> <td style="text-align: center; padding: 5px;">75Ω</td> </tr> <tr> <td style="padding: 5px;">Frequency Range</td> <td style="text-align: center; padding: 5px;">DC to 4GHz</td> </tr> <tr> <td style="padding: 5px;">VSWR</td> <td style="text-align: center; padding: 5px;">≤ 1.25 (DC To 4GHz)</td> </tr> <tr> <td style="padding: 5px;">Insulation Resistance</td> <td style="text-align: center; padding: 5px;">≥ 10000MΩ</td> </tr> <tr> <td style="padding: 5px;">Dielectric Withstanding Voltage (at sea level)</td> <td style="text-align: center; padding: 5px;">1500 V rms</td> </tr> <tr> <td style="padding: 5px;">Working Voltage (at sea level)</td> <td style="text-align: center; padding: 5px;">500 V rms</td> </tr> </table>		Electrical Data		Impedance	75Ω	Frequency Range	DC to 4GHz	VSWR	≤ 1.25 (DC To 4GHz)	Insulation Resistance	≥ 10000MΩ	Dielectric Withstanding Voltage (at sea level)	1500 V rms	Working Voltage (at sea level)	500 V rms
Electrical Data															
Impedance	75Ω														
Frequency Range	DC to 4GHz														
VSWR	≤ 1.25 (DC To 4GHz)														
Insulation Resistance	≥ 10000MΩ														
Dielectric Withstanding Voltage (at sea level)	1500 V rms														
Working Voltage (at sea level)	500 V rms														
<table border="1" style="width: 100%; border-collapse: collapse;"> <tr> <td style="width: 30%; padding: 5px;">Mechanical Data</td> <td></td> </tr> <tr> <td style="padding: 5px;">Recommended Coupling Nut Torque</td> <td style="text-align: center; padding: 5px;">15 to 20 in-lbs</td> </tr> <tr> <td style="padding: 5px;">Coupling Proof Torque</td> <td style="text-align: center; padding: 5px;">60 in-lbs</td> </tr> <tr> <td style="padding: 5px;">Durability (mating)</td> <td style="text-align: center; padding: 5px;">≥ 500</td> </tr> <tr> <td style="padding: 5px;">Accepts male pin size</td> <td style="text-align: center; padding: 5px;">Φ0.64~Φ1.07 (Φ.025~Φ.042)</td> </tr> </table>		Mechanical Data		Recommended Coupling Nut Torque	15 to 20 in-lbs	Coupling Proof Torque	60 in-lbs	Durability (mating)	≥ 500	Accepts male pin size	Φ0.64~Φ1.07 (Φ.025~Φ.042)				
Mechanical Data															
Recommended Coupling Nut Torque	15 to 20 in-lbs														
Coupling Proof Torque	60 in-lbs														
Durability (mating)	≥ 500														
Accepts male pin size	Φ0.64~Φ1.07 (Φ.025~Φ.042)														
<table border="1" style="width: 100%; border-collapse: collapse;"> <tr> <td style="width: 30%; padding: 5px;">Environmental Data</td> <td></td> </tr> <tr> <td style="padding: 5px;">Temperature Range</td> <td style="text-align: center; padding: 5px;">-40°C to +80°C</td> </tr> <tr> <td style="padding: 5px;">Thermal Shock</td> <td style="text-align: center; padding: 5px;">MIL-STD-202, Method 107, Condition B</td> </tr> <tr> <td style="padding: 5px;">Moisture Resistance</td> <td style="text-align: center; padding: 5px;">MIL-STD-202, Method 206</td> </tr> <tr> <td style="padding: 5px;">Corrosion</td> <td style="text-align: center; padding: 5px;">MIL-STD-202, Method 101, Condition B</td> </tr> <tr> <td style="padding: 5px;">RoHS</td> <td style="text-align: center; padding: 5px;">Compliant</td> </tr> </table>		Environmental Data		Temperature Range	-40°C to +80°C	Thermal Shock	MIL-STD-202, Method 107, Condition B	Moisture Resistance	MIL-STD-202, Method 206	Corrosion	MIL-STD-202, Method 101, Condition B	RoHS	Compliant		
Environmental Data															
Temperature Range	-40°C to +80°C														
Thermal Shock	MIL-STD-202, Method 107, Condition B														
Moisture Resistance	MIL-STD-202, Method 206														
Corrosion	MIL-STD-202, Method 101, Condition B														
RoHS	Compliant														

Notice: JYEBAO reserves the right to make modifications deemed appropriate.

AD-F3F8

SoftPlot Measurement Presentation
VSWR S11

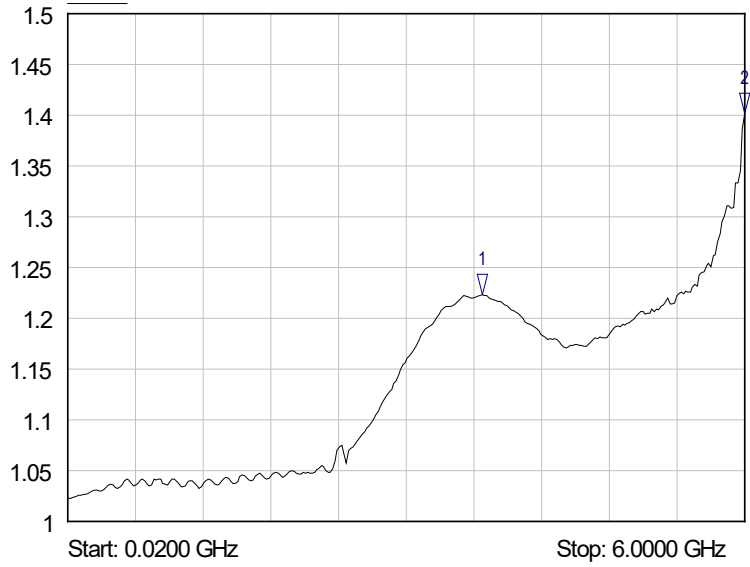

- 1 S11
▽ 3.6800 GHz
1.22 VSWR
- 2 S11
▽ 6.0000 GHz
1.40 VSWR