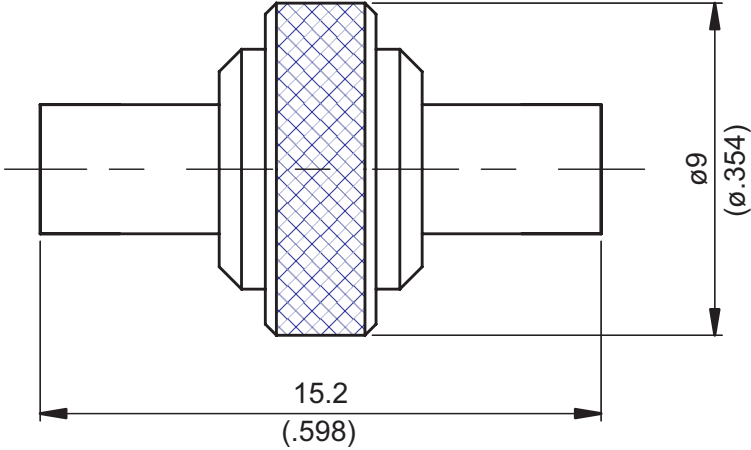

AD-E8E8	MMCX Jack To MMCX Jack 6GHz VSWR 1.2		50Ω
			
Parts	Material	Plating (Micro-inch)	
Contact Pin	Beryllium Copper	Gold 4 Over Nickel-Phosphorus Alloy 80 Over Copper 20	
Insulator	Teflon		
Body	Brass	Gold 4 Over Nickel-Phosphorus Alloy 80 Over Copper 20	
Weight: 2.51 g			

This part number complies with RoHS.

Notice: JYEBAO reserves the right to make modifications deemed appropriate.

AD-E8E8	MMCX Jack To MMCX Jack 6GHz VSWR 1.2																
<table border="0"> <tr> <td data-bbox="113 342 531 394"><b>Interface</b></td> <td></td> </tr> <tr> <td data-bbox="113 394 531 510">Standard</td> <td data-bbox="531 394 1482 510">IEC 61169-52</td> </tr> </table>		<b>Interface</b>		Standard	IEC 61169-52												
<b>Interface</b>																	
Standard	IEC 61169-52																
<table border="0"> <tr> <td data-bbox="113 528 531 580"><b>Electrical Data</b></td> <td></td> </tr> <tr> <td data-bbox="113 580 531 631">Impedance</td> <td data-bbox="531 580 1482 631">50Ω</td> </tr> <tr> <td data-bbox="113 631 531 683">Frequency Range</td> <td data-bbox="531 631 1482 683">DC to 6GHz</td> </tr> <tr> <td data-bbox="113 683 531 734">VSWR</td> <td data-bbox="531 683 1482 734">≤ 1.2 (DC To 6GHz)</td> </tr> <tr> <td data-bbox="113 734 531 786">Insertion Loss</td> <td data-bbox="531 734 1482 786">≤ 0.06 x √f(GHz) dB</td> </tr> <tr> <td data-bbox="113 786 531 837">Insulation Resistance</td> <td data-bbox="531 786 1482 837">≥ 10000MΩ</td> </tr> <tr> <td data-bbox="113 837 531 889">Dielectric Withstanding Voltage (at sea level)</td> <td data-bbox="531 837 1482 889">500 V rms</td> </tr> <tr> <td data-bbox="113 889 531 940">Working Voltage (at sea level)</td> <td data-bbox="531 889 1482 940">170 V rms</td> </tr> </table>		<b>Electrical Data</b>		Impedance	50Ω	Frequency Range	DC to 6GHz	VSWR	≤ 1.2 (DC To 6GHz)	Insertion Loss	≤ 0.06 x √f(GHz) dB	Insulation Resistance	≥ 10000MΩ	Dielectric Withstanding Voltage (at sea level)	500 V rms	Working Voltage (at sea level)	170 V rms
<b>Electrical Data</b>																	
Impedance	50Ω																
Frequency Range	DC to 6GHz																
VSWR	≤ 1.2 (DC To 6GHz)																
Insertion Loss	≤ 0.06 x √f(GHz) dB																
Insulation Resistance	≥ 10000MΩ																
Dielectric Withstanding Voltage (at sea level)	500 V rms																
Working Voltage (at sea level)	170 V rms																
<table border="0"> <tr> <td data-bbox="113 976 531 1028"><b>Mechanical Data</b></td> <td></td> </tr> <tr> <td data-bbox="113 1028 531 1079">Engagement Force</td> <td data-bbox="531 1028 1482 1079">≤ 3.4 lbs</td> </tr> <tr> <td data-bbox="113 1079 531 1131">Disengagement Force</td> <td data-bbox="531 1079 1482 1131">1.4 to 3.4 lbs</td> </tr> <tr> <td data-bbox="113 1131 531 1182">Contact Captivation-axial</td> <td data-bbox="531 1131 1482 1182">≥ 2.3 lbs</td> </tr> <tr> <td data-bbox="113 1182 531 1234">Durability (mating)</td> <td data-bbox="531 1182 1482 1234">≥ 500</td> </tr> </table>		<b>Mechanical Data</b>		Engagement Force	≤ 3.4 lbs	Disengagement Force	1.4 to 3.4 lbs	Contact Captivation-axial	≥ 2.3 lbs	Durability (mating)	≥ 500						
<b>Mechanical Data</b>																	
Engagement Force	≤ 3.4 lbs																
Disengagement Force	1.4 to 3.4 lbs																
Contact Captivation-axial	≥ 2.3 lbs																
Durability (mating)	≥ 500																
<table border="0"> <tr> <td data-bbox="113 1335 531 1386"><b>Environmental Data</b></td> <td></td> </tr> <tr> <td data-bbox="113 1386 531 1438">Temperature Range</td> <td data-bbox="531 1386 1482 1438">-65°C to +165°C</td> </tr> <tr> <td data-bbox="113 1438 531 1489">Thermal Shock</td> <td data-bbox="531 1438 1482 1489">MIL-STD-202, Method 107, Condition B</td> </tr> <tr> <td data-bbox="113 1489 531 1541">Moisture Resistance</td> <td data-bbox="531 1489 1482 1541">MIL-STD-202, Method 206</td> </tr> <tr> <td data-bbox="113 1541 531 1592">Corrosion</td> <td data-bbox="531 1541 1482 1592">MIL-STD-202, Method 101, Condition B</td> </tr> <tr> <td data-bbox="113 1592 531 1644">RoHS</td> <td data-bbox="531 1592 1482 1644">Compliant</td> </tr> </table>		<b>Environmental Data</b>		Temperature Range	-65°C to +165°C	Thermal Shock	MIL-STD-202, Method 107, Condition B	Moisture Resistance	MIL-STD-202, Method 206	Corrosion	MIL-STD-202, Method 101, Condition B	RoHS	Compliant				
<b>Environmental Data</b>																	
Temperature Range	-65°C to +165°C																
Thermal Shock	MIL-STD-202, Method 107, Condition B																
Moisture Resistance	MIL-STD-202, Method 206																
Corrosion	MIL-STD-202, Method 101, Condition B																
RoHS	Compliant																

Notice: JYEBAO reserves the right to make modifications deemed appropriate.