

AD-DI8DI8-P4A	7/16 jack to 7/16 jack with 4-hole flange 8GHz VSWR 1.2	50Ω
---------------	--	-----

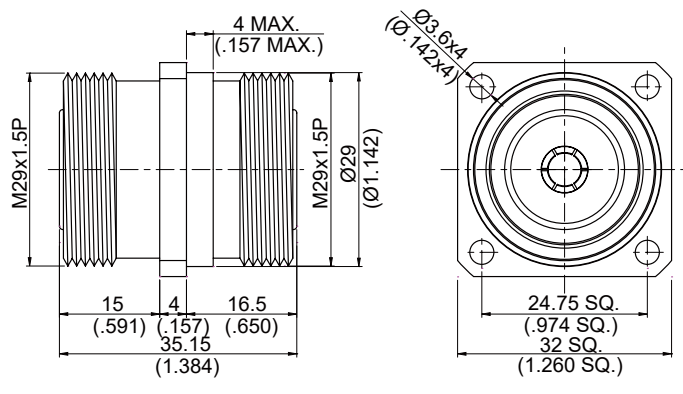

MOUNTING HOLE

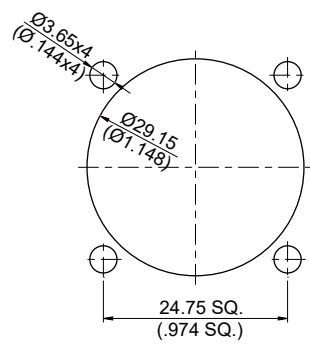

Parts	Material	Plating (Micro-inch)
Contact Pin	Phosphor Bronze	Gold 4 Over Nickel-Phosphorus Alloy 80 Over Copper 20
Insulator	Teflon	
Body	Brass	Tin-Zinc-Copper-Alloy 100 Over Copper 50

This part number complies with RoHS.
 Notice: JYEBAO reserves the right to make modifications deemed appropriate.

AD-DI8DI8-P4A	7/16 jack to 7/16 jack with 4-hole flange 8GHz VSWR 1.2																
<table border="0"> <tr> <td data-bbox="113 324 531 394">Interface</td> <td data-bbox="531 324 1482 394"></td> </tr> <tr> <td data-bbox="113 394 531 539">Standard</td> <td data-bbox="531 394 1482 539">IEC60169-4</td> </tr> </table>		Interface		Standard	IEC60169-4												
Interface																	
Standard	IEC60169-4																
<table border="0"> <tr> <td data-bbox="113 539 531 609">Electrical Data</td> <td data-bbox="531 539 1482 609"></td> </tr> <tr> <td data-bbox="113 609 531 656">Impedance</td> <td data-bbox="531 609 1482 656">50Ω</td> </tr> <tr> <td data-bbox="113 656 531 703">Frequency Range</td> <td data-bbox="531 656 1482 703">DC to 8GHz</td> </tr> <tr> <td data-bbox="113 703 531 750">VSWR</td> <td data-bbox="531 703 1482 750">≤ 1.2 (DC To 8GHz)</td> </tr> <tr> <td data-bbox="113 750 531 797">Insertion Loss</td> <td data-bbox="531 750 1482 797">≤ 0.04 x √f(GHz) dB</td> </tr> <tr> <td data-bbox="113 797 531 844">Insulation Resistance</td> <td data-bbox="531 797 1482 844">≥ 10000MΩ</td> </tr> <tr> <td data-bbox="113 844 531 891">Dielectric Withstanding Voltage (at sea level)</td> <td data-bbox="531 844 1482 891">4000 V rms</td> </tr> <tr> <td data-bbox="113 891 531 938">Working Voltage (at sea level)</td> <td data-bbox="531 891 1482 938">2700 V rms</td> </tr> </table>		Electrical Data		Impedance	50Ω	Frequency Range	DC to 8GHz	VSWR	≤ 1.2 (DC To 8GHz)	Insertion Loss	≤ 0.04 x √f(GHz) dB	Insulation Resistance	≥ 10000MΩ	Dielectric Withstanding Voltage (at sea level)	4000 V rms	Working Voltage (at sea level)	2700 V rms
Electrical Data																	
Impedance	50Ω																
Frequency Range	DC to 8GHz																
VSWR	≤ 1.2 (DC To 8GHz)																
Insertion Loss	≤ 0.04 x √f(GHz) dB																
Insulation Resistance	≥ 10000MΩ																
Dielectric Withstanding Voltage (at sea level)	4000 V rms																
Working Voltage (at sea level)	2700 V rms																
<table border="0"> <tr> <td data-bbox="113 1037 531 1106">Mechanical Data</td> <td data-bbox="531 1037 1482 1106"></td> </tr> <tr> <td data-bbox="113 1106 531 1153">Recommended Coupling Nut Torque</td> <td data-bbox="531 1106 1482 1153">260 in-lbs</td> </tr> <tr> <td data-bbox="113 1153 531 1200">Coupling Proof Torque</td> <td data-bbox="531 1153 1482 1200">310 in-lbs</td> </tr> <tr> <td data-bbox="113 1200 531 1247">Contact Captivation-axial</td> <td data-bbox="531 1200 1482 1247">≥ 45 lbs</td> </tr> <tr> <td data-bbox="113 1247 531 1294">Durability (mating)</td> <td data-bbox="531 1247 1482 1294">≥ 500</td> </tr> </table>		Mechanical Data		Recommended Coupling Nut Torque	260 in-lbs	Coupling Proof Torque	310 in-lbs	Contact Captivation-axial	≥ 45 lbs	Durability (mating)	≥ 500						
Mechanical Data																	
Recommended Coupling Nut Torque	260 in-lbs																
Coupling Proof Torque	310 in-lbs																
Contact Captivation-axial	≥ 45 lbs																
Durability (mating)	≥ 500																
<table border="0"> <tr> <td data-bbox="113 1435 531 1505">Environmental Data</td> <td data-bbox="531 1435 1482 1505"></td> </tr> <tr> <td data-bbox="113 1505 531 1552">Temperature Range</td> <td data-bbox="531 1505 1482 1552">-65°C to +165°C</td> </tr> <tr> <td data-bbox="113 1552 531 1599">Thermal Shock</td> <td data-bbox="531 1552 1482 1599">MIL-STD-202, Method 107, Condition B</td> </tr> <tr> <td data-bbox="113 1599 531 1646">Moisture Resistance</td> <td data-bbox="531 1599 1482 1646">MIL-STD-202, Method 206</td> </tr> <tr> <td data-bbox="113 1646 531 1693">Corrosion</td> <td data-bbox="531 1646 1482 1693">MIL-STD-202, Method 101, Condition B</td> </tr> <tr> <td data-bbox="113 1693 531 1740">RoHS</td> <td data-bbox="531 1693 1482 1740">Compliant</td> </tr> </table>		Environmental Data		Temperature Range	-65°C to +165°C	Thermal Shock	MIL-STD-202, Method 107, Condition B	Moisture Resistance	MIL-STD-202, Method 206	Corrosion	MIL-STD-202, Method 101, Condition B	RoHS	Compliant				
Environmental Data																	
Temperature Range	-65°C to +165°C																
Thermal Shock	MIL-STD-202, Method 107, Condition B																
Moisture Resistance	MIL-STD-202, Method 206																
Corrosion	MIL-STD-202, Method 101, Condition B																
RoHS	Compliant																

Notice: JYEBAO reserves the right to make modifications deemed appropriate.