

AD-B8J8-P2	BNC Jack to BMA Jack with 2-hole Flange 4GHz VSWR 1.2	50Ω
------------	--	-----

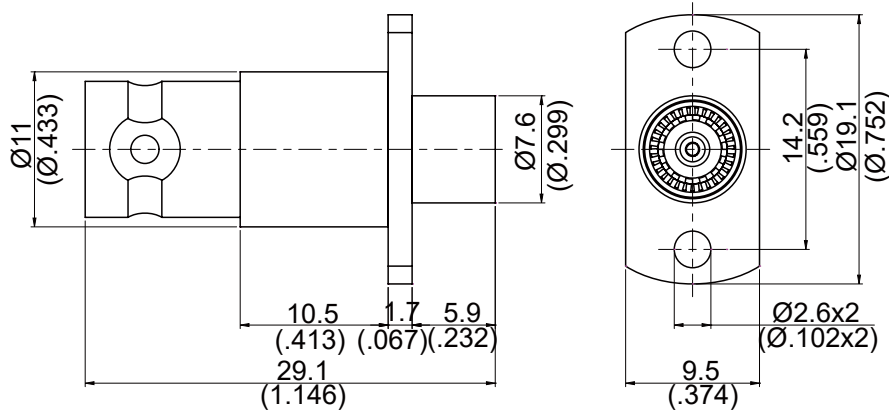

MOUNTING HOLE:

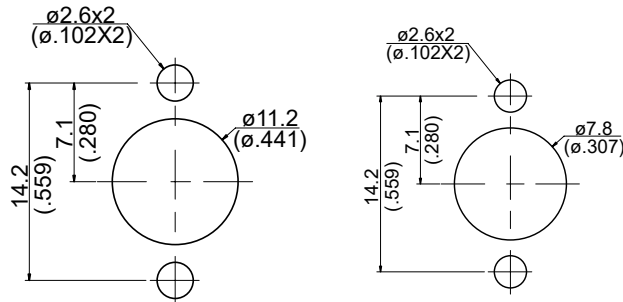

Parts	Material	Plating (Micro-inch)
Contact Body	Brass	Gold 4 Over Nickel-Phosphorus Alloy 80 Over Copper 20
Spring Washer	Beryllium Copper	Gold 4 Over Nickel-Phosphorus Alloy 80 Over Copper 20
Spring Ring	Beryllium Copper	Gold 4 Over Nickel-Phosphorus Alloy 80 Over Copper 20
Contact Pin	Beryllium Copper	Gold 4 Over Nickel-Phosphorus Alloy 80 Over Copper 20
Insulator	Teflon	
Body	Brass	Tin-Zinc-Copper-Alloy 100 Over Copper 50

Weight:

This part number complies with RoHS.

Notice: JYEBAO reserves the right to make modifications deemed appropriate.

AD-B8J8-P2		BNC Jack to BMA Jack with 2-hole Flange 4GHz VSWR 1.2	
Interface		BNC	BMA
Standard		MIL-STD-348B	MIL-STD-348B
Electrical Data			
Impedance	50Ω		
Frequency Range	DC To 4GHz		
VSWR	≤ 1.2 (DC To 4GHz)		
Insertion Loss	≤ 0.05 x √f(GHz) dB		
Insulation Resistance	≥ 5000MΩ		
Dielectric Withstanding Voltage (at sea level)	1500 V rms		
Working Voltage (at sea level)	500 V rms		
Mechanical Data			
	BNC	BMA	
Recommended Coupling Nut Torque	0.6 to 2.5 in-lbs	NA	
Engagement Force	NA	≤ 3 lbs	
Disengagement Force	NA	≤ 1.5 lbs	
Contact Captivation-axial	≥ 6.1 lbs	≥ 6.1 lbs	
Durability (mating)	≥ 500	≥ 1000	
Environmental Data			
Temperature Range	-65°C to +165°C		
Thermal Shock	MIL-STD-202, Method 107, Condition B		
Moisture Resistance	MIL-STD-202, Method 206		
Corrosion	MIL-STD-202, Method 101, Condition B		
RoHS	Compliant		

Notice: JYEBAO reserves the right to make modifications deemed appropriate.