

AD-A8T6	SMA Jack to TNC Reverse Polarity Plug 6GHz VSWR 1.2	50Ω
---------	--	-----

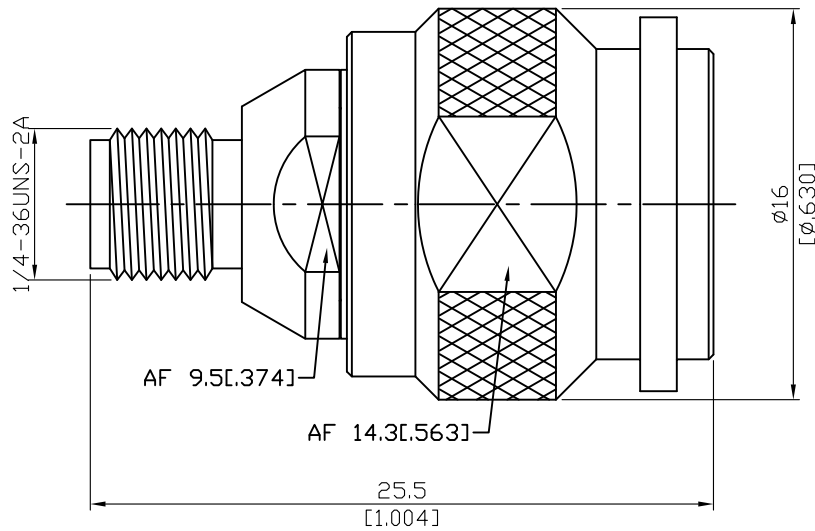

Parts	Material	Plating (Micro-inch)
Contact Pin	Beryllium Copper	Gold 4 Over Nickel-Phosphorus Alloy 80 Over Copper 20
Gasket	Silicone	
Body (TNC)	Brass	Tin-Zinc-Copper-Alloy 100 Over Copper 50
Retainer Ring	Brass	Tin-Zinc-Copper-Alloy 100 Over Copper 50
Insulator	Teflon	
Body (SMA)	Brass	Gold 4 Over Nickel-Phosphorus Alloy 80 Over Copper 20
Coupling Nut (TNC)	Brass	Tin-Zinc-Copper-Alloy 100 Over Copper 50

--	--

This part number complies with RoHS.

Notice: JYEBAO reserves the right to make modifications deemed appropriate.

AD-A8T6	SMA Jack To TNC Reverse Polarity Plug 6GHz VSWR 1.2																			
<div data-bbox="129 344 531 394" style="border: 1px solid black; padding: 2px;">Interface</div> <p>SMA Standard Polarity Jack Side: Per MIL-STD-348B; Mechanically compatible with 2.92 & 3.5</p> <p>TNC Reverse Polarity Plug Side: Per JYEBAO TNC Reverse Polarity Plug derived from MIL-STD-348B</p>																				
<div data-bbox="129 698 531 748" style="border: 1px solid black; padding: 2px;">Electrical Data</div> <table border="0" style="width: 100%;"> <tr> <td style="width: 50%;">Impedance</td> <td style="width: 50%;">50Ω</td> </tr> <tr> <td>Frequency Range</td> <td>DC To 6GHz</td> </tr> <tr> <td>VSWR</td> <td>≤ 1.2 (DC To 6GHz)</td> </tr> <tr> <td>Insertion Loss</td> <td>≤ 0.05 x √f(GHz) dB</td> </tr> <tr> <td>Insulation Resistance</td> <td>≥ 5000MΩ</td> </tr> <tr> <td>Dielectric Withstanding Voltage (at sea level)</td> <td>1500 V rms</td> </tr> <tr> <td>Working Voltage (at sea level)</td> <td>500 V rms</td> </tr> </table>			Impedance	50Ω	Frequency Range	DC To 6GHz	VSWR	≤ 1.2 (DC To 6GHz)	Insertion Loss	≤ 0.05 x √f(GHz) dB	Insulation Resistance	≥ 5000MΩ	Dielectric Withstanding Voltage (at sea level)	1500 V rms	Working Voltage (at sea level)	500 V rms				
Impedance	50Ω																			
Frequency Range	DC To 6GHz																			
VSWR	≤ 1.2 (DC To 6GHz)																			
Insertion Loss	≤ 0.05 x √f(GHz) dB																			
Insulation Resistance	≥ 5000MΩ																			
Dielectric Withstanding Voltage (at sea level)	1500 V rms																			
Working Voltage (at sea level)	500 V rms																			
<div data-bbox="129 1198 531 1247" style="border: 1px solid black; padding: 2px;">Mechanical Data</div> <table border="0" style="width: 100%;"> <tr> <td style="width: 50%;"></td> <td style="width: 25%; text-align: center; border-bottom: 1px solid black;">SMA</td> <td style="width: 25%; text-align: center; border-bottom: 1px solid black;">TNC</td> </tr> <tr> <td>Recommended Coupling Nut Torque</td> <td style="text-align: center;">4 in-lbs</td> <td style="text-align: center;">4.1 to 6.1 in-lbs</td> </tr> <tr> <td>Coupling Proof Torque</td> <td style="text-align: center;">5.3 in-lbs</td> <td style="text-align: center;">15 in-lbs</td> </tr> <tr> <td>Coupling Nut Retention Force</td> <td style="text-align: center;">NA</td> <td style="text-align: center;">≥ 101.2 lbs</td> </tr> <tr> <td>Contact Captivation-axial</td> <td style="text-align: center;">≥ 6.1 lbs</td> <td style="text-align: center;">≥ 6.1 lbs</td> </tr> <tr> <td>Durability (mating)</td> <td style="text-align: center;">≥ 100</td> <td style="text-align: center;">≥ 500</td> </tr> </table>		SMA	TNC	Recommended Coupling Nut Torque	4 in-lbs	4.1 to 6.1 in-lbs	Coupling Proof Torque	5.3 in-lbs	15 in-lbs	Coupling Nut Retention Force	NA	≥ 101.2 lbs	Contact Captivation-axial	≥ 6.1 lbs	≥ 6.1 lbs	Durability (mating)	≥ 100	≥ 500		
	SMA	TNC																		
Recommended Coupling Nut Torque	4 in-lbs	4.1 to 6.1 in-lbs																		
Coupling Proof Torque	5.3 in-lbs	15 in-lbs																		
Coupling Nut Retention Force	NA	≥ 101.2 lbs																		
Contact Captivation-axial	≥ 6.1 lbs	≥ 6.1 lbs																		
Durability (mating)	≥ 100	≥ 500																		
<div data-bbox="129 1601 531 1650" style="border: 1px solid black; padding: 2px;">Environmental Data</div> <table border="0" style="width: 100%;"> <tr> <td style="width: 50%;">Temperature Range</td> <td style="width: 50%;">-65°C to +165°C</td> </tr> <tr> <td>Thermal Shock</td> <td>MIL-STD-202, Method</td> </tr> <tr> <td>Moisture Resistance</td> <td>MIL-STD-202, Method</td> </tr> <tr> <td>Corrosion</td> <td>MIL-STD-202, Method</td> </tr> <tr> <td>RoHS</td> <td>Compliant</td> </tr> </table>			Temperature Range	-65°C to +165°C	Thermal Shock	MIL-STD-202, Method	Moisture Resistance	MIL-STD-202, Method	Corrosion	MIL-STD-202, Method	RoHS	Compliant								
Temperature Range	-65°C to +165°C																			
Thermal Shock	MIL-STD-202, Method																			
Moisture Resistance	MIL-STD-202, Method																			
Corrosion	MIL-STD-202, Method																			
RoHS	Compliant																			

AD-A8T6

