

AD-A8N9

**SMA Jack To N Reverse Polarity Jack**  
**6GHz VSWR 1.2**

50Ω

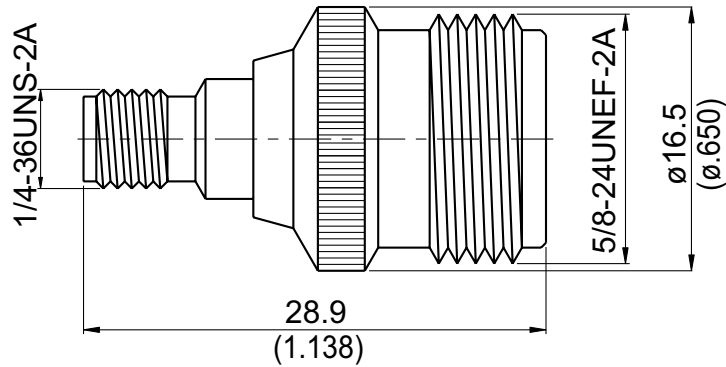

Parts	Material	Plating (Micro-inch)
Center Pin	Beryllium Copper	Gold 4 Over Nickel-Phosphorus Alloy 80 Over Copper 20
Insulator	Teflon	
Body(SMA)	Brass	Gold 4 Over Nickel-Phosphorus Alloy 80 Over Copper 20
Body(N)	Brass	Tin-Zinc-Copper-Alloy 100 Over Copper 50

Weight: 20.05 g

**This part number complies with RoHS.**

**Notice: JYEBAO reserves the right to make modifications deemed appropriate.**

AD-A8N9	SMA Jack To N Reverse Polarity Jack 6GHz VSWR 1.2																
<div data-bbox="129 344 531 394" style="border: 1px solid black; padding: 2px;">Interface</div> <p>SMA Standard Polarity Jack Side: Per MIL-STD-348B; Mechanically compatible with 2.92 &amp; 3.5</p> <p>N Reverse Polarity Jack Side: Per JYEBAO N Reverse Polarity Jack derived from MIL-STD-348B</p>																	
<div data-bbox="129 698 531 748" style="border: 1px solid black; padding: 2px;">Electrical Data</div> <table border="0" style="width: 100%;"> <tr> <td style="width: 50%;">Impedance</td> <td style="width: 50%;">50Ω</td> </tr> <tr> <td>Frequency Range</td> <td>DC To 6GHz</td> </tr> <tr> <td>VSWR</td> <td>≤ 1.2 (DC To 6GHz)</td> </tr> <tr> <td>Insertion Loss</td> <td>≤ 0.04 x √f(GHz) dB</td> </tr> <tr> <td>Insulation Resistance</td> <td>≥ 5000MΩ</td> </tr> <tr> <td>Dielectric Withstanding Voltage (at sea level)</td> <td>1500 V rms</td> </tr> <tr> <td>Working Voltage (at sea level)</td> <td>500 V rms</td> </tr> </table>			Impedance	50Ω	Frequency Range	DC To 6GHz	VSWR	≤ 1.2 (DC To 6GHz)	Insertion Loss	≤ 0.04 x √f(GHz) dB	Insulation Resistance	≥ 5000MΩ	Dielectric Withstanding Voltage (at sea level)	1500 V rms	Working Voltage (at sea level)	500 V rms	
Impedance	50Ω																
Frequency Range	DC To 6GHz																
VSWR	≤ 1.2 (DC To 6GHz)																
Insertion Loss	≤ 0.04 x √f(GHz) dB																
Insulation Resistance	≥ 5000MΩ																
Dielectric Withstanding Voltage (at sea level)	1500 V rms																
Working Voltage (at sea level)	500 V rms																
<div data-bbox="129 1198 531 1247" style="border: 1px solid black; padding: 2px;">Mechanical Data</div> <table border="0" style="width: 100%; border-collapse: collapse;"> <thead> <tr> <th style="width: 50%;"></th> <th style="width: 25%; text-align: center; border-bottom: 1px solid black;">SMA</th> <th style="width: 25%; text-align: center; border-bottom: 1px solid black;">N</th> </tr> </thead> <tbody> <tr> <td style="border-right: 1px solid black;">Recommended Coupling Nut Torque</td> <td style="text-align: center; border-right: 1px solid black;">4 in-lbs</td> <td style="text-align: center;">6 to 10 in-lbs</td> </tr> <tr> <td style="border-right: 1px solid black;">Coupling Proof Torque</td> <td style="text-align: center; border-right: 1px solid black;">5.3 in-lbs</td> <td style="text-align: center;">15 in-lbs</td> </tr> <tr> <td style="border-right: 1px solid black;">Contact Captivation-axial</td> <td style="text-align: center; border-right: 1px solid black;">≥ 6.1 lbs</td> <td style="text-align: center;">≥ 6.3 lbs</td> </tr> <tr> <td style="border-right: 1px solid black;">Durability (mating)</td> <td style="text-align: center; border-right: 1px solid black;">≥ 100</td> <td style="text-align: center;">≥ 500</td> </tr> </tbody> </table>				SMA	N	Recommended Coupling Nut Torque	4 in-lbs	6 to 10 in-lbs	Coupling Proof Torque	5.3 in-lbs	15 in-lbs	Contact Captivation-axial	≥ 6.1 lbs	≥ 6.3 lbs	Durability (mating)	≥ 100	≥ 500
	SMA	N															
Recommended Coupling Nut Torque	4 in-lbs	6 to 10 in-lbs															
Coupling Proof Torque	5.3 in-lbs	15 in-lbs															
Contact Captivation-axial	≥ 6.1 lbs	≥ 6.3 lbs															
Durability (mating)	≥ 100	≥ 500															
<div data-bbox="129 1646 531 1695" style="border: 1px solid black; padding: 2px;">Environmental Data</div> <table border="0" style="width: 100%;"> <tr> <td style="width: 50%;">Temperature Range</td> <td style="width: 50%;">-65°C to +165°C</td> </tr> <tr> <td>Thermal Shock</td> <td>MIL-STD-202, Method 107, Condition B</td> </tr> <tr> <td>Moisture Resistance</td> <td>MIL-STD-202, Method 206</td> </tr> <tr> <td>Corrosion</td> <td>MIL-STD-202, Method 101, Condition B</td> </tr> <tr> <td>RoHS</td> <td>Compliant</td> </tr> </table>			Temperature Range	-65°C to +165°C	Thermal Shock	MIL-STD-202, Method 107, Condition B	Moisture Resistance	MIL-STD-202, Method 206	Corrosion	MIL-STD-202, Method 101, Condition B	RoHS	Compliant					
Temperature Range	-65°C to +165°C																
Thermal Shock	MIL-STD-202, Method 107, Condition B																
Moisture Resistance	MIL-STD-202, Method 206																
Corrosion	MIL-STD-202, Method 101, Condition B																
RoHS	Compliant																

# AD-A8N9

SoftPlot Measurement Presentation  
S11

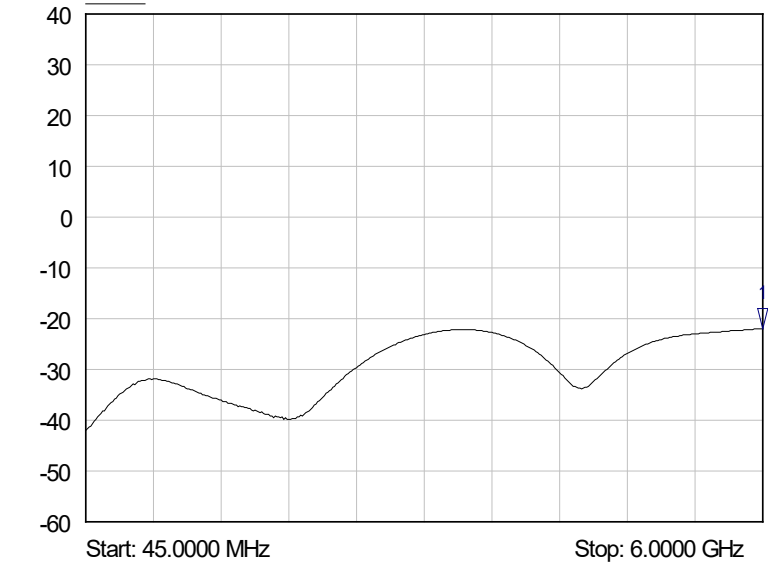

1 S11  
▽ 6.0000 GHz  
-21.94 dB