

AD-A8N3A-18

SMA Jack To N Plug
18GHz VSWR 1.15

50Ω

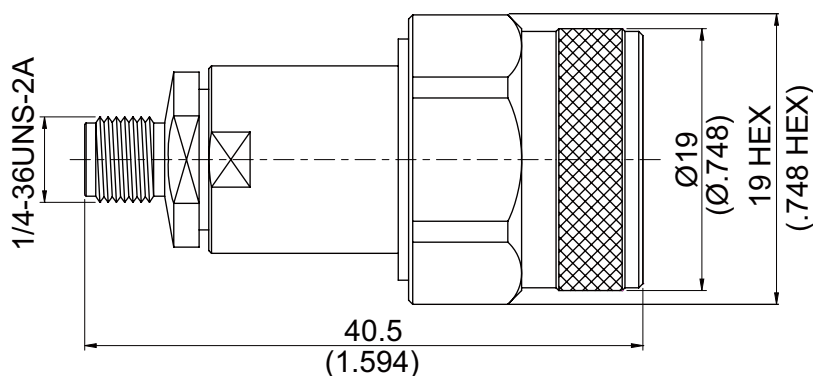

Parts	Material	Plating (Micro-inch)
Contact Pin	Beryllium Copper	Gold 4 Over Nickel-Phosphorus Alloy 80 Over Copper 20
Body(SMA)	Brass	Gold 4 Over Nickel-Phosphorus Alloy 80 Over Copper 20
Retainer Ring	Brass	Tin-Zinc-Copper-Alloy 100 Over Copper 50
Gasket	Silicone	
Insulator(N)	PPO	
Insulator(SMA)	Teflon	
Coupling Nut	Brass	Tin-Zinc-Copper-Alloy 100 Over Copper 50
Body (N)	Brass	Tin-Zinc-Copper-Alloy 100 Over Copper 50

This part number complies with RoHS.

Notice: JYEBAO reserves the right to make modifications deemed appropriate.

AD-A8N3A-18	SMA Jack To N Plug 18GHz VSWR 1.15																						
<div style="border: 1px solid black; padding: 2px; margin-bottom: 5px;">Interface</div> Standard Mechanically compatible with	<table border="1" style="width: 100%; border-collapse: collapse;"> <thead> <tr> <th style="width: 50%;">SMA</th> <th style="width: 50%;">N</th> </tr> </thead> <tbody> <tr> <td>MIL-STD-348B</td> <td>MIL-STD-348B</td> </tr> <tr> <td>2.92 & 3.5</td> <td></td> </tr> </tbody> </table>	SMA	N	MIL-STD-348B	MIL-STD-348B	2.92 & 3.5																	
SMA	N																						
MIL-STD-348B	MIL-STD-348B																						
2.92 & 3.5																							
<div style="border: 1px solid black; padding: 2px; margin-bottom: 5px;">Electrical Data</div> Impedance Frequency Range VSWR Insertion Loss Insulation Resistance Dielectric Withstanding Voltage (at sea level) Working Voltage (at sea level)	<table style="width: 100%;"> <tbody> <tr> <td style="width: 50%;">Impedance</td> <td colspan="2">50Ω</td> </tr> <tr> <td>Frequency Range</td> <td colspan="2">DC To 18GHz</td> </tr> <tr> <td>VSWR</td> <td colspan="2">≤ 1.15 (DC To 18GHz)</td> </tr> <tr> <td>Insertion Loss</td> <td colspan="2">≤ 0.04 x √f(GHz) dB</td> </tr> <tr> <td>Insulation Resistance</td> <td colspan="2">≥ 5000MΩ</td> </tr> <tr> <td>Dielectric Withstanding Voltage (at sea level)</td> <td colspan="2">1500 V rms</td> </tr> <tr> <td>Working Voltage (at sea level)</td> <td colspan="2">500 V rms</td> </tr> </tbody> </table>		Impedance	50Ω		Frequency Range	DC To 18GHz		VSWR	≤ 1.15 (DC To 18GHz)		Insertion Loss	≤ 0.04 x √f(GHz) dB		Insulation Resistance	≥ 5000MΩ		Dielectric Withstanding Voltage (at sea level)	1500 V rms		Working Voltage (at sea level)	500 V rms	
Impedance	50Ω																						
Frequency Range	DC To 18GHz																						
VSWR	≤ 1.15 (DC To 18GHz)																						
Insertion Loss	≤ 0.04 x √f(GHz) dB																						
Insulation Resistance	≥ 5000MΩ																						
Dielectric Withstanding Voltage (at sea level)	1500 V rms																						
Working Voltage (at sea level)	500 V rms																						
<div style="border: 1px solid black; padding: 2px; margin-bottom: 5px;">Mechanical Data</div> Recommended Coupling Nut Torque Coupling Proof Torque Coupling Nut Retention Force Contact Captivation-axial Durability (mating)	<table border="1" style="width: 100%; border-collapse: collapse;"> <thead> <tr> <th style="width: 50%;"></th> <th style="width: 25%;">SMA</th> <th style="width: 25%;">N</th> </tr> </thead> <tbody> <tr> <td>Recommended Coupling Nut Torque</td> <td>4 in-lbs</td> <td>6 to 10 in-lbs</td> </tr> <tr> <td>Coupling Proof Torque</td> <td>5.3 in-lbs</td> <td>15 in-lbs</td> </tr> <tr> <td>Coupling Nut Retention Force</td> <td>NA</td> <td>≥ 101.2 lbs</td> </tr> <tr> <td>Contact Captivation-axial</td> <td>≥ 6.1 lbs</td> <td>≥ 6.3 lbs</td> </tr> <tr> <td>Durability (mating)</td> <td>≥ 100</td> <td>≥ 500</td> </tr> </tbody> </table>			SMA	N	Recommended Coupling Nut Torque	4 in-lbs	6 to 10 in-lbs	Coupling Proof Torque	5.3 in-lbs	15 in-lbs	Coupling Nut Retention Force	NA	≥ 101.2 lbs	Contact Captivation-axial	≥ 6.1 lbs	≥ 6.3 lbs	Durability (mating)	≥ 100	≥ 500			
	SMA	N																					
Recommended Coupling Nut Torque	4 in-lbs	6 to 10 in-lbs																					
Coupling Proof Torque	5.3 in-lbs	15 in-lbs																					
Coupling Nut Retention Force	NA	≥ 101.2 lbs																					
Contact Captivation-axial	≥ 6.1 lbs	≥ 6.3 lbs																					
Durability (mating)	≥ 100	≥ 500																					
<div style="border: 1px solid black; padding: 2px; margin-bottom: 5px;">Environmental Data</div> Temperature Range Thermal Shock Moisture Resistance Corrosion RoHS	<table style="width: 100%;"> <tbody> <tr> <td style="width: 50%;">Temperature Range</td> <td colspan="2">-55°C to +105°C</td> </tr> <tr> <td>Thermal Shock</td> <td colspan="2">MIL-STD-202, Method 107, Condition B</td> </tr> <tr> <td>Moisture Resistance</td> <td colspan="2">MIL-STD-202, Method 206</td> </tr> <tr> <td>Corrosion</td> <td colspan="2">MIL-STD-202, Method 101, Condition B</td> </tr> <tr> <td>RoHS</td> <td colspan="2">Compliant</td> </tr> </tbody> </table>		Temperature Range	-55°C to +105°C		Thermal Shock	MIL-STD-202, Method 107, Condition B		Moisture Resistance	MIL-STD-202, Method 206		Corrosion	MIL-STD-202, Method 101, Condition B		RoHS	Compliant							
Temperature Range	-55°C to +105°C																						
Thermal Shock	MIL-STD-202, Method 107, Condition B																						
Moisture Resistance	MIL-STD-202, Method 206																						
Corrosion	MIL-STD-202, Method 101, Condition B																						
RoHS	Compliant																						

Notice: JYEBAO reserves the right to make modifications deemed appropriate.

AD-A8N3A-18

SoftPlot Measurement Presentation

dB S11 S21 S12 S22

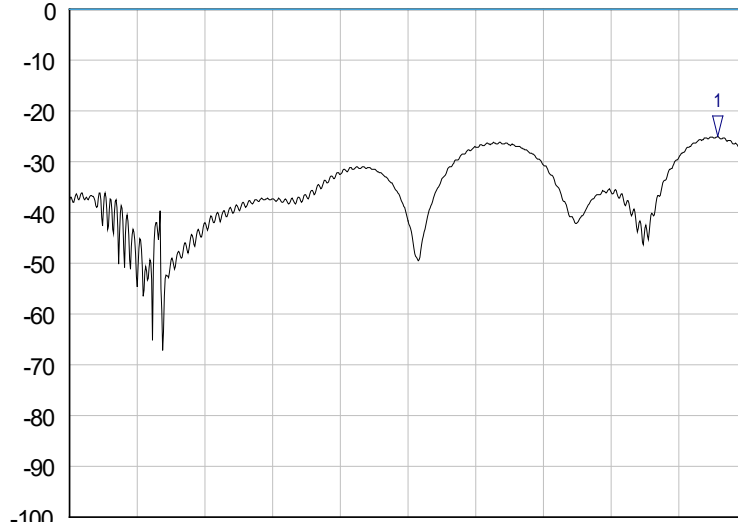

Start: 100.0000 MHz

Stop: 18.0000 GHz

1 S11
▽ 17.2393 GHz
1.12 VSWR