

AD-A8B3

SMA Jack To BNC Plug
7GHz VSWR 1.2

50Ω

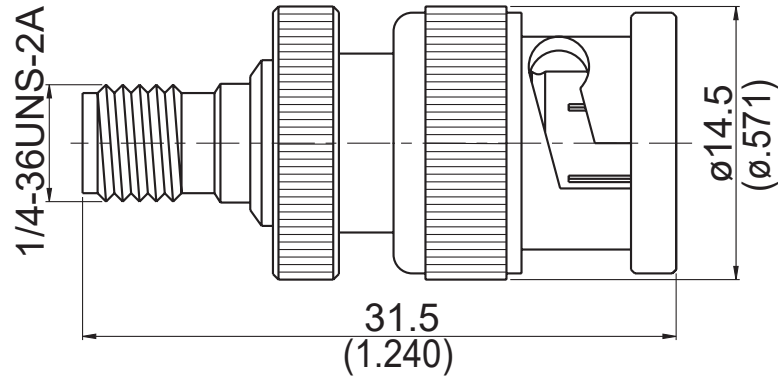

Parts	Material	Plating (Micro-inch)
Gasket	Silicon	
Spring	SK 5	Tin-Zinc-Copper-Alloy 100 Over Copper 50
Washer	Brass	Tin-Zinc-Copper-Alloy 100 Over Copper 50
Body(SMA)	Brass	Gold 4 Over Nickel-Phosphorus Alloy 80 Over Copper 20
Center Pin	Beryllium Copper	Gold 4 Over Nickel-Phosphorus Alloy 80 Over Copper 20
Insulator	Teflon	
Body(BNC)	Brass	Tin-Zinc-Copper-Alloy 100 Over Copper 50
Coupling Nut(BNC)	Brass	Tin-Zinc-Copper-Alloy 100 Over Copper 50

Weight: 14.93 g

This part number complies with RoHS.

Notice: JYEBAO reserves the right to make modifications deemed appropriate.

AD-A8B3	SMA Jack To BNC Plug 7GHz VSWR 1.2													
<div style="border: 1px solid black; padding: 2px; margin-bottom: 5px;">Interface</div> Standard Mechanically compatible with	<table border="1" style="width: 100%; border-collapse: collapse;"> <thead> <tr> <th style="width: 50%;">SMA</th> <th style="width: 50%;">BNC</th> </tr> </thead> <tbody> <tr> <td>MIL-STD-348B</td> <td>MIL-STD-348B</td> </tr> <tr> <td>2.92 & 3.5</td> <td></td> </tr> </tbody> </table>	SMA	BNC	MIL-STD-348B	MIL-STD-348B	2.92 & 3.5								
SMA	BNC													
MIL-STD-348B	MIL-STD-348B													
2.92 & 3.5														
<div style="border: 1px solid black; padding: 2px; margin-bottom: 5px;">Electrical Data</div> Impedance Frequency Range VSWR Insertion Loss Insulation Resistance Dielectric Withstanding Voltage (at sea level) Working Voltage (at sea level)	<table style="width: 100%;"> <tbody> <tr> <td style="width: 50%;">50Ω</td> <td style="width: 50%;">DC To 7GHz</td> </tr> <tr> <td>≤ 1.2 (DC To 7GHz)</td> <td></td> </tr> <tr> <td>≤ 0.05 x √f(GHz) dB</td> <td></td> </tr> <tr> <td>≥ 5000MΩ</td> <td></td> </tr> <tr> <td>1500 V rms</td> <td></td> </tr> <tr> <td>500 V rms</td> <td></td> </tr> </tbody> </table>		50Ω	DC To 7GHz	≤ 1.2 (DC To 7GHz)		≤ 0.05 x √f(GHz) dB		≥ 5000MΩ		1500 V rms		500 V rms	
50Ω	DC To 7GHz													
≤ 1.2 (DC To 7GHz)														
≤ 0.05 x √f(GHz) dB														
≥ 5000MΩ														
1500 V rms														
500 V rms														
<div style="border: 1px solid black; padding: 2px; margin-bottom: 5px;">Mechanical Date</div> Recommended Coupling Nut Torque Coupling Proof Torque Coupling Nut Retention Force Contact Captivation-axial Durability (mating)	<table border="1" style="width: 100%; border-collapse: collapse;"> <thead> <tr> <th style="width: 50%;">SMA</th> <th style="width: 50%;">BNC</th> </tr> </thead> <tbody> <tr> <td>4 in-lbs</td> <td>0.6 to 2.5 in-lbs</td> </tr> <tr> <td>5.3 in-lbs</td> <td>NA</td> </tr> <tr> <td>NA</td> <td>≥ 101.2 lbs</td> </tr> <tr> <td>≥ 6.1 lbs</td> <td>≥ 6.1 lbs</td> </tr> <tr> <td>≥ 100</td> <td>≥ 500</td> </tr> </tbody> </table>	SMA	BNC	4 in-lbs	0.6 to 2.5 in-lbs	5.3 in-lbs	NA	NA	≥ 101.2 lbs	≥ 6.1 lbs	≥ 6.1 lbs	≥ 100	≥ 500	
SMA	BNC													
4 in-lbs	0.6 to 2.5 in-lbs													
5.3 in-lbs	NA													
NA	≥ 101.2 lbs													
≥ 6.1 lbs	≥ 6.1 lbs													
≥ 100	≥ 500													
<div style="border: 1px solid black; padding: 2px; margin-bottom: 5px;">Environmental Data</div> Temperature Range Thermal Shock Moisture Resistance Corrosion RoHS	<table style="width: 100%;"> <tbody> <tr> <td style="width: 50%;">-65°C to +165°C</td> <td style="width: 50%;">MIL-STD-202, Method</td> </tr> <tr> <td></td> <td>MIL-STD-202, Method</td> </tr> <tr> <td></td> <td>MIL-STD-202, Method</td> </tr> <tr> <td></td> <td>Compliant</td> </tr> </tbody> </table>		-65°C to +165°C	MIL-STD-202, Method		MIL-STD-202, Method		MIL-STD-202, Method		Compliant				
-65°C to +165°C	MIL-STD-202, Method													
	MIL-STD-202, Method													
	MIL-STD-202, Method													
	Compliant													

Notice: JYEBAO reserves the right to make modifications deemed appropriate.

AD-A8B3

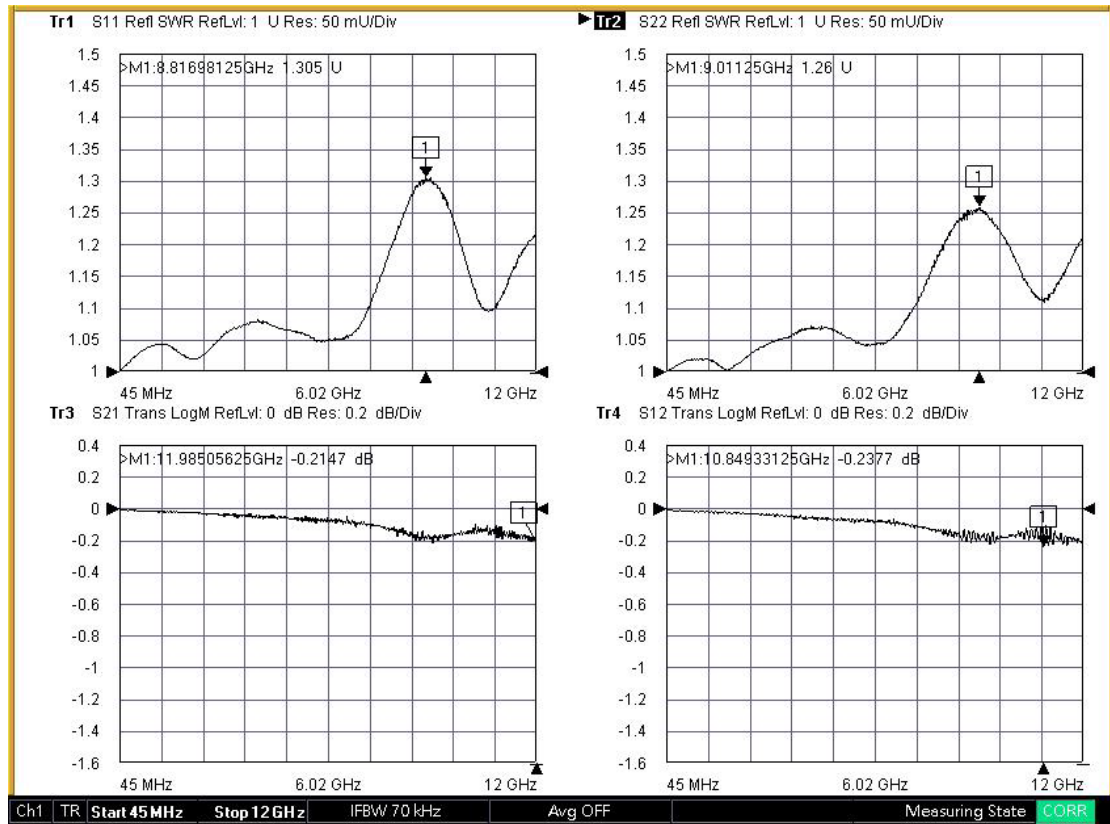

Note: S11/S12/S21/S22 plots shown represent IL and VSWR of two adaptors tested. To extract IL of a single adaptor divide IL measured by two.