

NO.	COMPONENTS	IMPEDANCE
1	SMA FEMALE RIGHT ANGLE	50 OHM
2	6003A	50 OHM
3	HEAT SHRINKING TUBE	
4	SLEEVE	
5	N FEMALE	50 OHM

REVISION			
REV.	DESCRIPTON	DATE	APPROVED
-	INITIAL RELEASE	2021/01/15	

SMA FEMALE
RIGHT ANGLE

N FEMALE

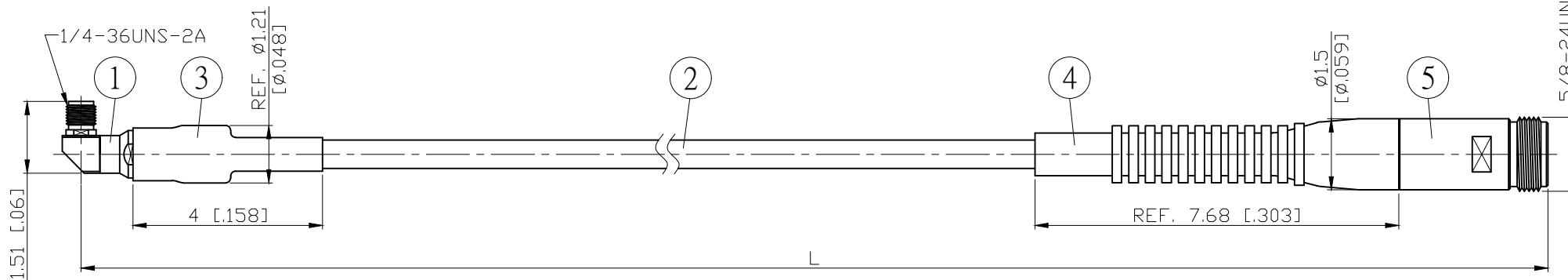

L CM (INCH)	L1 M (MM)
50 (19.685)	0.472 (471.5)
100 (39.370)	0.972 (971.5)
150 (59.055)	1.472 (1471.5)
200 (78.740)	1.972 (1971.5)
Custom length in CM	- - -

Spec	Phase stability vs bending ⁽¹⁾	Amplitude stability vs bending ⁽²⁾	Max VSWR	Max IL	Flexure life cycle ⁽³⁾
3GHz	±0.5° typ / ±1.0° max	±0.005dB typ / ±0.01dB max	1.12 : 1	≤ (0.0075dB/cm*Lcm)+0.15dB	≥ 20000
6GHz	±0.75° typ / ±1.5° max	±0.0075dB typ / ±0.015dB max	1.15 : 1	≤ (0.0115dB/cm*Lcm)+0.20dB	
12.4GHz	±1.0° typ / ±2.0° max	±0.01dB typ / ±0.02dB max	1.20 : 1	≤ (0.0185dB/cm*Lcm)+0.25dB	
18GHz	±1.5° typ / ±3.0° max	±0.015dB typ / ±0.03dB max	1.25 : 1	≤ (0.0230dB/cm*Lcm)+0.30dB	

Notes:

- Operating Temp.: -40°C / +85°C
- Static bend radius 18mm
- Dynamic bend radius 60mm
- RoHS Compliant

- Per IEC 60966-1, section 8.6, method 1
- Per IEC 60966-1, section 8.4
- Per IEC 60966-1, section 9.3

NO.	PARTS NO.	DESCRIPTION	Q'TY	U/M	LENGTH TOLERANCE IS ±1.5% OR ±10MM, WHICHEVER IS GREATER.	STANDARD	REV -	UNIT CM(INCH)	JYE BAO CO., LTD. TAIPEI TAIWAN
5	N8200S-6003	N JACK	1	EA		APPROVED		DATE	DESCRIPTION CABLE ASSEMBLY SMA JACK R/A TO N JACK JYE BAO DRAWING NO. A89N80-63-18GXXX
4	600-SLEEVE	SLEEVE	1	EA		CHECKED		DATE	
3	G5(F)-12MM-BLACK	TUBE	0.04	M		DRAWING	<i>Albert</i>	DATE	
2	6003A	CABLE	SEE TABLE L1	M					
1	SMA8200S-M6003	SMA JACK R/A	1	EA					