

NO.	COMPONENTS	IMPEDANCE
1	SMA MALE RIGHT ANGLE	50 OHM
2	5002	50 OHM
3	HEAT SHRINKING TUBE	
4	SMP FEMALE RIGHT ANGLE	50 OHM

REVISION			
REV.	DESCRIPTION	DATE	APPROVED
-	INITIAL RELEASE	2022/03/22	

SMA MALE
RIGHT ANGLE

SMP FEMALE
RIGHT ANGLE

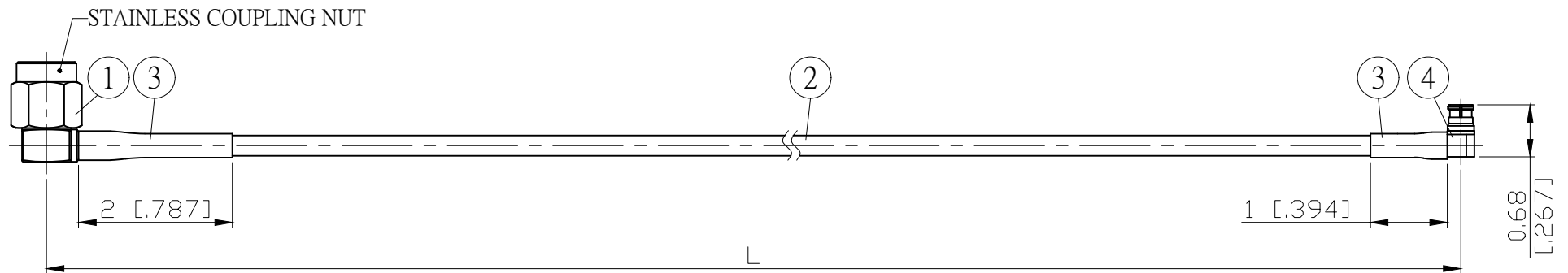

L CM (INCH)	L1 M (MM)
50 (19.685)	0.501 (501.0)
100 (39.370)	1.001 (1001.0)
150 (59.055)	1.501 (1501.0)
200 (78.740)	2.001 (2001.0)
Custom length in CM	- - -

Spec	Phase stability vs bending ⁽¹⁾	Amplitude stability vs bending ⁽²⁾	Max VSWR	Max IL	Flexure life cycle ⁽³⁾
3GHz	±0.3° typ / ±0.5° max	±0.005dB typ / ±0.01dB max	1.20 : 1	≤ (0.0128dB/cm*Lcm)+0.15dB	≥ 10000
6GHz	±0.5° typ / ±0.75° max	±0.0075dB typ / ±0.015dB max	1.25 : 1	≤ (0.0189dB/cm*Lcm)+0.20dB	
12.4GHz	±0.75° typ / ±1.0° max	±0.010dB typ / ±0.02dB max	1.30 : 1	≤ (0.0293dB/cm*Lcm)+0.25dB	
18GHz	±1.0° typ / ±1.5° max	±0.015dB typ / ±0.03dB max	1.35 : 1	≤ (0.0361dB/cm*Lcm)+0.30dB	

Notes:

- Operating Temp.: -55°C / +125°C
- Static bend radius 5.1mm
- Dynamic bend radius 30mm
- RoHS Compliant

- (1) Per IEC 60966-1, section 8.6, method 1
- (2) Per IEC 60966-1, section 8.4
- (3) Per IEC 60966-1, section 9.3

					STANDARD	REV -	UNIT CM(INCH)	JYE BAO CO., LTD.	
					APPROVED			TAIPEI TAIWAN	
					CHECKED			DESCRIPTION	
					DRAWING			CABLE ASSEMBLY SMA PLUG R/A TO SMP JACK R/A	
					<i>Albert</i>				JYE BAO DRAWING NO.
									A39P89-52L-18GXXX
4	SMP8300-9085	SMP JACK R/A	1	EA	LENGTH TOLERANCE IS ±1.5% OR ±10MM, WHICHEVER IS GREATER.				
3	G5(F)-4.0MM-BLACK	TUBE	0.03	M					
2	5002	CABLE	SEE TABLE L1	M					
1	SMA33NPC-9405	SMA PLUG R/A	1	EA					
NO.	PARTS NO.	DESCRIPTION	Q'TY	U/M					