

| NO. | COMPONENTS | IMPEDANCE |
|-----|-----------------------|-----------|
| 1 | SMA MALE RIGHT ANGLE | 50 OHM |
| 2 | RG316 | 50 OHM |
| 3 | HEAT SHRINKING TUBE | |
| 4 | N FEMALE FOR BULKHEAD | 50 OHM |

| REVISION | | | |
|----------|-----------------|------------|----------|
| REV. | DESCRIPTION | DATE | APPROVED |
| - | INITIAL RELEASE | 2011/03/15 | |

SMA MALE
RIGHT ANGLE

N FEMALE
FOR BULKHEAD

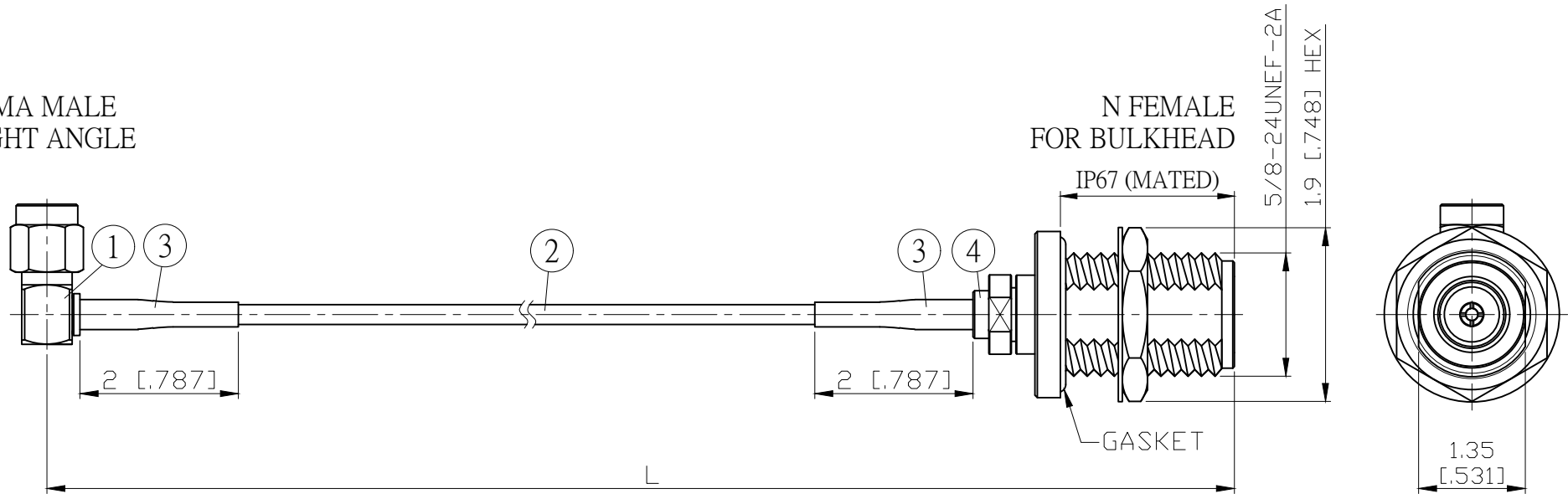

| JYE BAO P/N | L CM (INCH) | L1 FT (MM) |
|----------------|------------------------|----------------|
| A39N85-316-15 | 15 (5.906) | 0.438 (133.5) |
| A39N85-316-30 | 30 (11.811) | 0.930 (283.5) |
| A39N85-316-50 | 50 (19.685) | 1.586 (483.5) |
| A39N85-316-100 | 100 (39.370) | 3.227 (983.5) |
| A39N85-316-150 | 150 (59.055) | 4.867 (1483.5) |
| A39N85-316-200 | 200 (78.740) | 6.508 (1983.5) |
| A39N85-316-XXX | CUSTOM LENGTH IN CM | - - - |

MOUNTING HOLE

| | | | | |
|-----|-------------------|--------------|----------------|----|
| 4 | N8105P-0316 | N JACK | 1 | EA |
| 3 | G5(F)-4.0MM-BLACK | TUBE | 0.04 | M |
| 2 | RG316 | CABLE | L1 (SEE TABLE) | FT |
| 1 | SMA3100-9316 | SMA PLUG R/A | 1 | EA |
| NO. | PARTS NO. | DESCRIPTION | QTY | UM |

DIMENSION ARE MILLIMETERS
UNLESS OTHERWISE SPECIFIED
TOLERANCES (UNIT: MM)

LENGTH TOLERANCE
IS ±1.5% OR ±10MM,
WHICHEVER IS
GREATER.

| STANDARD | REV | UNIT |
|----------|--------|----------|
| | - | CM(INCH) |
| APPROVED | | DATE |
| CHECKED | | DATE |
| DRAWING | Albert | DATE |

JYE BAO CO., LTD.

TAIPEI TAIWAN

DESCRIPTION CABLE ASSEMBLY SMA PLUG R/A
TO N JACK FOR BULKHEAD

JYE BAO DRAWING NO.

A39N85-316-XXX