

NO.	COMPONENTS	IMPEDANCE
1	SMA MALE RIGHT ANGLE	50 OHM
2	6003A	50 OHM
3	HEAT SHRINKING TUBE	

REVISION			
REV.	DESCRIPTON	DATE	APPROVED
-	INITIAL RELEASE	2021/01/15	

SMA MALE
RIGHT ANGLE

SMA MALE
RIGHT ANGLE

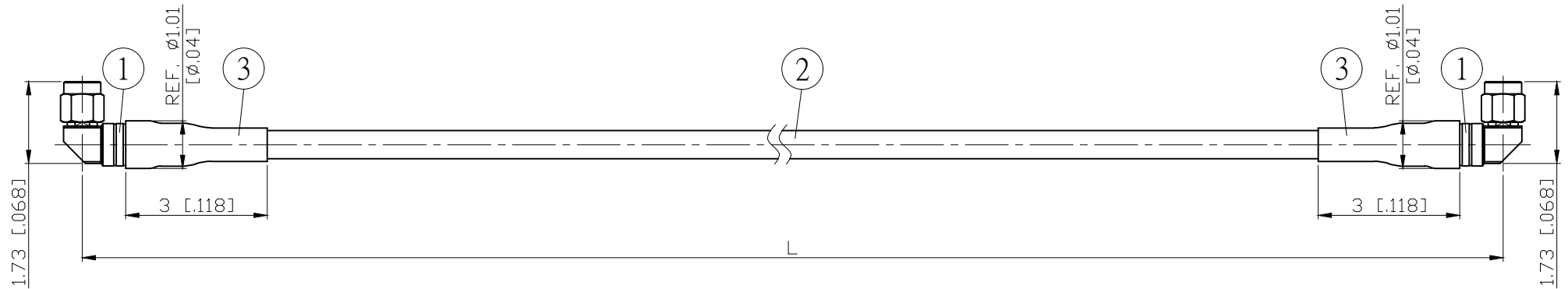

L CM (INCH)	L1 M (MM)
50 (19.685)	0.487 (486.5)
100 (39.370)	0.987 (986.5)
150 (59.055)	1.487 (1486.5)
200 (78.740)	1.987 (1986.5)
Custom length in CM	- - -

Spec	Phase stability vs bending ⁽¹⁾	Amplitude stability vs bending ⁽²⁾	Max VSWR	Max IL	Flexure life cycle ⁽³⁾
3GHz	±0.5° typ / ±1.0° max	±0.005dB typ / ±0.01dB max	1.12 : 1	≤ (0.0075dB/cm*Lcm)+0.15dB	≥ 20000
6GHz	±0.75° typ / ±1.5° max	±0.0075dB typ / ±0.015dB max	1.15 : 1	≤ (0.0115dB/cm*Lcm)+0.20dB	
12.4GHz	±1.0° typ / ±2.0° max	±0.01dB typ / ±0.02dB max	1.20 : 1	≤ (0.0185dB/cm*Lcm)+0.25dB	
18GHz	±1.5° typ / ±3.0° max	±0.015dB typ / ±0.03dB max	1.25 : 1	≤ (0.0230dB/cm*Lcm)+0.30dB	

Notes:

- Operating Temp.: -40°C / +85°C
- Static bend radius 18mm
- Dynamic bend radius 60mm
- RoHS Compliant

- Per IEC 60966-1, section 8.6, method 1
- Per IEC 60966-1, section 8.4
- Per IEC 60966-1, section 9.3

3	G5(F)-12MM-BLACK	TUBE	0.06	M	LENGTH TOLERANCE IS ±1.5% OR ±10MM, WHICHEVER IS GREATER.	STANDARD	REV	-	UNIT	CM(INCH)	JYE BAO CO., LTD. TAIPEI TAIWAN		
	2	6003A	SEE TABLE L1	M		APPROVED	DATE						
	1	SMA3200S-M6003	SMA PLUG R/A	2		EA	CHECKED	DATE				DESCRIPTION	CABLE ASSEMBLY SMA PLUG R/A TO SMA PLUG R/A
	NO.	PARTS NO.	DESCRIPTION	Q'TY		U/M	DRAWING	DATE					JYE BAO DRAWING NO.

Albert