

NO.	COMPONENTS	IMPEDANCE
1	SMA MALE RIGHT ANGLE	50 OHM
2	5002	50 OHM
3	HEAT SHRINKING TUBE	

REVISION			
REV.	DESCRIPTON	DATE	APPROVED
-	INITIAL RELEASE	2020/12/30	

TEST LEAD WITH EXTRA STURDY CABLE / CONNECTOR CONNECTION.

SMA MALE
RIGHT ANGLE

SMA MALE
RIGHT ANGLE

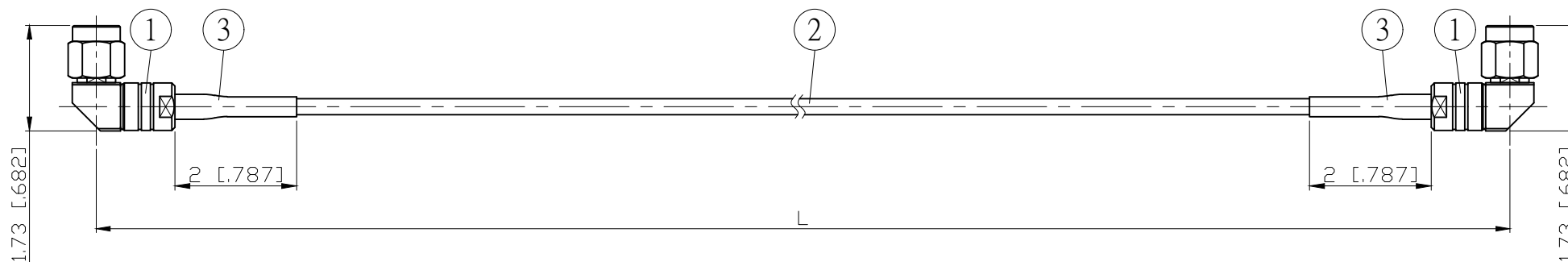

L CM (INCH)	L1 M (MM)
50 (19.685)	0.485 (484.5)
100 (39.370)	0.985 (984.5)
150 (59.055)	1.485 (1484.5)
200 (78.740)	1.985 (1984.5)
Custom length in CM	- - -

Spec	Phase stability vs bending ⁽¹⁾	Amplitude stability vs bending ⁽²⁾	Max VSWR	Max IL	Flexure life cycle ⁽³⁾
3GHz	±0.3° typ / ±0.5° max	±0.005dB typ / ±0.01dB max	1.12 : 1	≤ (0.0128dB/cm*Lcm)+0.15dB	≥ 10000
6GHz	±0.5° typ / ±0.75° max	±0.0075dB typ / ±0.015dB max	1.15 : 1	≤ (0.0189dB/cm*Lcm)+0.20dB	
12.4GHz	±0.75° typ / ±1.0° max	±0.010dB typ / ±0.02dB max	1.20 : 1	≤ (0.0293dB/cm*Lcm)+0.25dB	
18GHz	±1.0° typ / ±1.5° max	±0.015dB typ / ±0.03dB max	1.25 : 1	≤ (0.0361dB/cm*Lcm)+0.30dB	

Notes:

- Operating Temp.: -55°C / +125°C
- Static bend radius 5.1mm
- Dynamic bend radius 30mm
- RoHS Compliant

- Per IEC 60966-1, section 8.6, method 1
- Per IEC 60966-1, section 8.4
- Per IEC 60966-1, section 9.3

				STANDARD	REV -	UNIT CM(INCH)	JYE BAO CO., LTD. TAIPEI TAIWAN
				APPROVED	DATE		
				CHECKED	DATE		
				DRAWING <i>Albert</i>	DATE		
3	G5(F)-4.0MM-BLACK	TUBE	0.04	M	DESCRIPTION CABLE ASSEMBLY SMA PLUG R/A TO SMA PLUG R/A		
2	5002	CABLE	SEE TABLE L1	M	JYE BAO DRAWING NO. A39A39-5002-18GXXX		
1	SMA3200S-M5002	SMA PLUG R/A	2	EA			
NO.	PARTS NO.	DESCRIPTION	Q'TY	U/M			