

NO.	COMPONENTS	IMPEDANCE
1	SMA MALE	50 OHM
2	5002	50 OHM
3	HEAT SHRINKING TUBE	
4	SMP FEMALE RIGHT ANGLE	50 OHM

REVISION			
REV.	DESCRIPTION	DATE	APPROVED
-	INITIAL RELEASE	2017/10/05	
A	REVISE NOTE	2022/05/04	

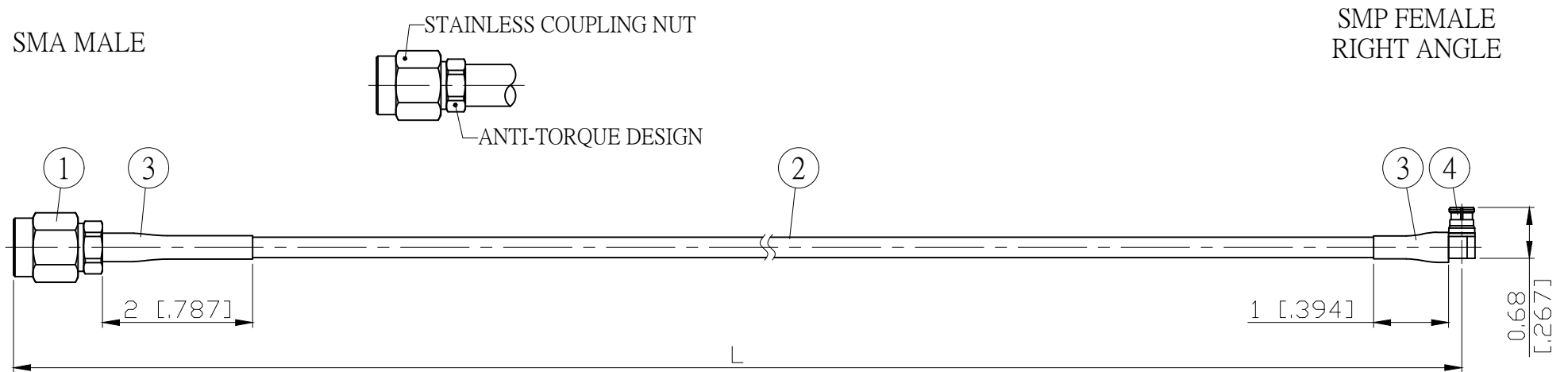

L CM (INCH)	L1 M (MM)
50 (19.685)	0.495 (494.5)
100 (39.370)	0.995 (994.5)
150 (59.055)	1.495 (1494.5)
200 (78.740)	1.995 (1994.5)
Custom length in CM	- - -

Spec	Phase stability vs bending ⁽¹⁾	Amplitude stability vs bending ⁽²⁾	Max VSWR	Max IL	Flexure life cycle ⁽³⁾
3GHz	±0.3° typ / ±0.5° max	±0.005dB typ / ±0.01dB max	1.20 : 1	≤ (0.0128dB/cm*Lcm)+0.15dB	≥ 10000
6GHz	±0.5° typ / ±0.75° max	±0.0075dB typ / ±0.015dB max	1.25 : 1	≤ (0.0189dB/cm*Lcm)+0.20dB	
12.4GHz	±0.75° typ / ±1.0° max	±0.010dB typ / ±0.02dB max	1.30 : 1	≤ (0.0293dB/cm*Lcm)+0.25dB	
18GHz	±1.0° typ / ±1.5° max	±0.015dB typ / ±0.03dB max	1.35 : 1	≤ (0.0361dB/cm*Lcm)+0.30dB	

Notes:

- Operating Temp.: -55°C / +125°C
- Static bend radius 5.1mm
- Dynamic bend radius 30mm
- RoHS Compliant

- (1) Per IEC 60966-1, section 8.6, method 1
- (2) Per IEC 60966-1, section 8.4
- (3) Per IEC 60966-1, section 9.3

					STANDARD	REV A	UNIT CM(INCH)	JYE BAO CO., LTD. TAIPEI TAIWAN
					APPROVED		DATE	
					CHECKED		DATE	
					DRAWING <i>Albert</i>		DATE	
4	SMP8300-9085	SMP JACK R/A	1	EA	LENGTH TOLERANCE IS ±1.5% OR ±10MM, WHICHEVER IS GREATER.			DESCRIPTION CABLE ASSEMBLY SMA PLUG TO SMP JACK R/A
3	G5(F)-4.0MM-BLACK	TUBE	0.03	M				JYE BAO DRAWING NO.
2	5002	CABLE	SEE TABLE L1	M				A30P89-52L-18GXXX
1	SMA33AT-0405	SMA PLUG	1	EA				
NO.	PARTS NO.	DESCRIPTION	Q'TY	U/M				