

NO.	COMPONENTS	IMPEDANCE
1	SMA MALE	50 OHM
2	6003A	50 OHM
3	SLEEVE	
4	HEAT SHRINKING TUBE	
5	SMA FEMALE RIGHT ANGLE	50 OHM

REVISION			
REV.	DESCRIPTON	DATE	APPROVED
-	INITIAL RELEASE	2021/01/15	

SMA MALE

SMA FEMALE  
RIGHT ANGLE

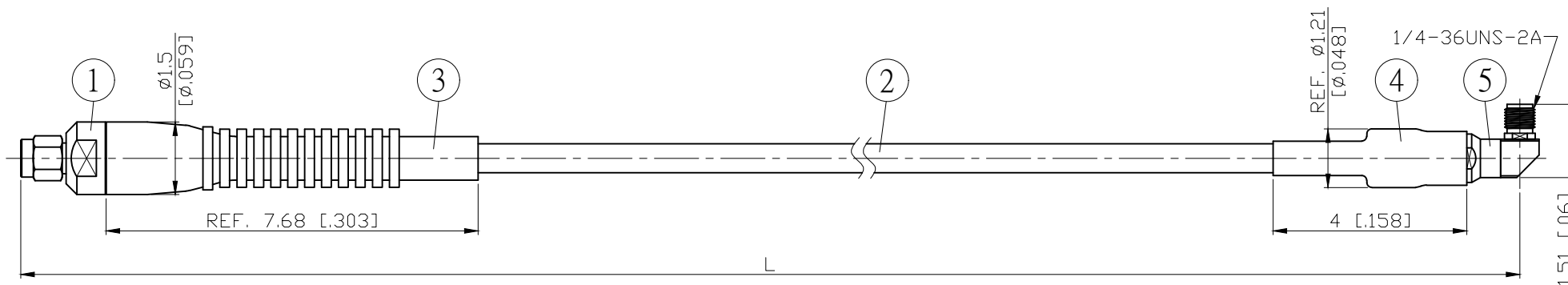

L CM (INCH)	L1 M (MM)
50 (19.685)	0.486 (486.0)
100 (39.370)	0.986 (986.0)
150 (59.055)	1.486 (1486.0)
200 (78.740)	1.986 (1986.0)
Custom length in CM	- - -

Spec	Phase stability vs bending <sup>(1)</sup>	Amplitude stability vs bending <sup>(2)</sup>	Max VSWR	Max IL	Flexure life cycle <sup>(3)</sup>
3GHz	±0.5° typ / ±1.0° max	±0.005dB typ / ±0.01dB max	1.12 : 1	≤ (0.0075dB/cm*Lcm)+0.15dB	≥ 20000
6GHz	±0.75° typ / ±1.5° max	±0.0075dB typ / ±0.015dB max	1.15 : 1	≤ (0.0115dB/cm*Lcm)+0.20dB	
12.4GHz	±1.0° typ / ±2.0° max	±0.01dB typ / ±0.02dB max	1.20 : 1	≤ (0.0185dB/cm*Lcm)+0.25dB	
18GHz	±1.5° typ / ±3.0° max	±0.015dB typ / ±0.03dB max	1.25 : 1	≤ (0.0230dB/cm*Lcm)+0.30dB	
27GHz	±2.0° typ / ±4.0° max	±0.02dB typ / ±0.04dB max	1.25 : 1	≤ (0.0285dB/cm*Lcm)+0.40dB	

Notes:

- Operating Temp.: -40°C / +85°C
- Static bend radius 18mm
- Dynamic bend radius 60mm
- RoHS Compliant

- Per IEC 60966-1, section 8.6, method 1
- Per IEC 60966-1, section 8.4
- Per IEC 60966-1, section 9.3

NO.	PARTS NO.	DESCRIPTION	Q'TY	U/M	STANDARD	REV	UNIT CM(INCH)	JYE BAO CO., LTD.	
5	SMA8200S-M6003	SMA JACK R/A	1	EA	APPROVED	-	DATE	TAIPEI TAIWAN	
4	G5(F)-12MM-BLACK	TUBE	0.04	M		CHECKED	DATE		DESCRIPTION
3	600-SLEEVE	SLEEVE	1	EA		DRAWING	DATE		JYE BAO DRAWING NO.
2	6003A	CABLE	SEE TABLE L1	M		<i>Albert</i>	DATE		A30A89-63A-27GXXX
1	SMA3200S-6003	SMA PLUG	1	EA					
LENGTH TOLERANCE IS ±1.5% OR ±10MM, WHICHEVER IS GREATER.									