

NO.	COMPONENTS	IMPEDANCE
1	SMA MALE	50 OHM
2	5005	50 OHM
3	HEAT SHRINKING TUBE	
4	SMA FEMALE FOR BULKHEAD	50 OHM

REVISION			
REV.	DESCRIPTON	DATE	APPROVED
-	INITIAL RELEASE	2020/12/30	

## TEST LEAD WITH EXTRA STURDY CABLE / CONNECTOR CONNECTION.

SMA MALE

SMA FEMALE  
FOR BULKHEAD

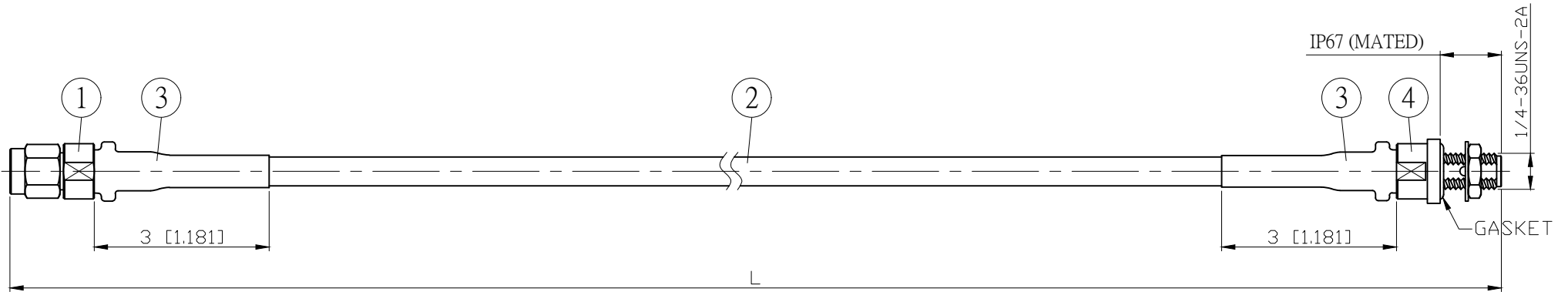

L CM (INCH)	L1 M (MM)
50 (19.685)	0.483 (483.0)
100 (39.370)	0.983 (983.0)
150 (59.055)	1.483 (1483.0)
200 (78.740)	1.983 (1983.0)
Custom length in CM	- - -

Spec	Phase stability vs bending <sup>(1)</sup>	Amplitude stability vs bending <sup>(2)</sup>	Max VSWR	Max IL	Flexure life cycle <sup>(3)</sup>
3GHz	±0.3° typ / ±0.5° max	±0.01dB typ / ±0.02dB max	1.15 : 1	≤ (0.0055dB/cm*Lcm)+0.15dB	≥ 10000
6GHz	±0.5° typ / ±1.0° max	±0.02dB typ / ±0.04dB max	1.20 : 1	≤ (0.0075dB/cm*Lcm)+0.20dB	
12.4GHz	±0.75° typ / ±1.5° max	±0.03dB typ / ±0.05dB max	1.25 : 1	≤ (0.0106dB/cm*Lcm)+0.25dB	
18GHz	±1.0° typ / ±2.0° max	±0.05dB typ / ±0.10dB max	1.30 : 1	≤ (0.0132dB/cm*Lcm)+0.30dB	

Notes:

- Operating Temp.: -55°C / +125°C
- Static bend radius 16mm
- Dynamic bend radius 70mm
- RoHS Compliant

- Per IEC 60966-1, section 8.6, method 1
- Per IEC 60966-1, section 8.4
- Per IEC 60966-1, section 9.3

MOUNTING HOLE  
(UNIT:CM)

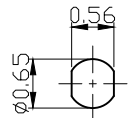

					STANDARD	REV -	UNIT CM(INCH)	<b>JYE BAO CO., LTD.</b>	
					APPROVED			TAIPEI TAIWAN	
					CHECKED		DATE	DESCRIPTION CABLE ASSEMBLY SMA PLUG TO SMA FEMALE FOR BULKHEAD	
					DRAWING	<i>Albert</i>	DATE	JYE BAO DRAWING NO. A30A85-5005-18GXXX	
4	SMA8205S-L142	SMA JACK	1	EA	LENGTH TOLERANCE IS ±1.5% OR ±10MM, WHICHEVER IS GREATER.				
3	G5(F)-10MM-BLACK	TUBE	0.06	M					
2	5005	CABLE	SEE TABLE L1	M					
1	SMA32NP-L142	SMA PLUG	1	EA					
NO.	PARTS NO.	DESCRIPTION	Q'TY	U/M					