

7/16-8346L-0250/FEP

7/16 Jack Solder Clamp 4 Hole Flange For .250 conformable with FEP jacket; 1.7GHz VSWR 1.2

50Ω

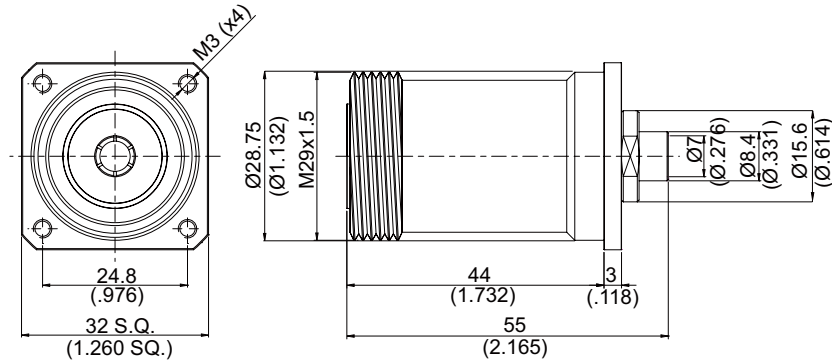

MOUNTING HOLE

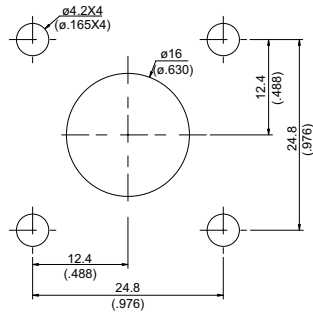

Parts	Material	Plating(Micro-inch)
Solder Ferrule	Brass	Gold 4 Over Nickel-Phosphorus Alloy 80 Over Copper 20
Nut	Brass	Tin-Zinc-Copper-Alloy 100 Over Copper 50
Barrel	Brass	Tin-Zinc-Copper-Alloy 100 Over Copper 50
Contact Pin	Phosphor Bronze	Silver 150 Over Copper 50
Insulator	Teflon	
Body	Brass	Tin-Zinc-Copper-Alloy 100 Over Copper 50

Weight: 156.85 g

Suitable Cables: .250 inch jacketed conformable cable

This part number complies with RoHS.

Notice: JYEBAO reserves the right to make modifications deemed appropriate.

7/16	7/16-8346L-0250/FEP																						
<table border="1" style="width: 100%;"> <tr> <td style="width: 30%;">Interface</td> <td></td> </tr> <tr> <td>IEC 60169-4</td> <td></td> </tr> </table>		Interface		IEC 60169-4																			
Interface																							
IEC 60169-4																							
<table border="1" style="width: 100%;"> <tr> <td style="width: 30%;">Electrical Data</td> <td></td> </tr> <tr> <td>Impedance</td> <td>50Ω</td> </tr> <tr> <td>Frequency range</td> <td>DC to 1.7GHz</td> </tr> <tr> <td>VSWR</td> <td>≦ 1.2 (DC to 1.7GHz)</td> </tr> <tr> <td>Insertion loss</td> <td>≦ 0.05dB</td> </tr> <tr> <td>Insulation resistance</td> <td>≧ 10000MΩ</td> </tr> <tr> <td>Contact resistance inner conductor</td> <td>≦ 0.4mΩ</td> </tr> <tr> <td>Contact resistance outer conductor</td> <td>≦ 1.5mΩ</td> </tr> <tr> <td>Dielectric withstanding voltage (at sea level)</td> <td>4000 V rms</td> </tr> <tr> <td>Working Voltage (at sea level)</td> <td>2700 V rms</td> </tr> <tr> <td>RF leakage</td> <td>≧ 128dB to 1GHz</td> </tr> </table>		Electrical Data		Impedance	50Ω	Frequency range	DC to 1.7GHz	VSWR	≦ 1.2 (DC to 1.7GHz)	Insertion loss	≦ 0.05dB	Insulation resistance	≧ 10000MΩ	Contact resistance inner conductor	≦ 0.4mΩ	Contact resistance outer conductor	≦ 1.5mΩ	Dielectric withstanding voltage (at sea level)	4000 V rms	Working Voltage (at sea level)	2700 V rms	RF leakage	≧ 128dB to 1GHz
Electrical Data																							
Impedance	50Ω																						
Frequency range	DC to 1.7GHz																						
VSWR	≦ 1.2 (DC to 1.7GHz)																						
Insertion loss	≦ 0.05dB																						
Insulation resistance	≧ 10000MΩ																						
Contact resistance inner conductor	≦ 0.4mΩ																						
Contact resistance outer conductor	≦ 1.5mΩ																						
Dielectric withstanding voltage (at sea level)	4000 V rms																						
Working Voltage (at sea level)	2700 V rms																						
RF leakage	≧ 128dB to 1GHz																						
<table border="1" style="width: 100%;"> <tr> <td style="width: 30%;">Mechanical Data</td> <td></td> </tr> <tr> <td>Recommended coupling nut torque</td> <td>260 inch lbs</td> </tr> <tr> <td>Coupling proof torque</td> <td>310 inch lbs</td> </tr> <tr> <td>Contact captivation-axial</td> <td>≧ 45 lbs</td> </tr> <tr> <td>Durability (mating)</td> <td>≧ 500</td> </tr> </table>		Mechanical Data		Recommended coupling nut torque	260 inch lbs	Coupling proof torque	310 inch lbs	Contact captivation-axial	≧ 45 lbs	Durability (mating)	≧ 500												
Mechanical Data																							
Recommended coupling nut torque	260 inch lbs																						
Coupling proof torque	310 inch lbs																						
Contact captivation-axial	≧ 45 lbs																						
Durability (mating)	≧ 500																						
<table border="1" style="width: 100%;"> <tr> <td style="width: 30%;">Environmental Data</td> <td></td> </tr> <tr> <td>Temperature range</td> <td>-65°C to +165°C</td> </tr> <tr> <td>Thermal shock</td> <td>MIL-STD-202, Method107, Condition B</td> </tr> <tr> <td>Moisture resistance</td> <td>MIL-STD-202, Method106</td> </tr> <tr> <td>Corrosion</td> <td>MIL-STD-202, Method101, Condition B</td> </tr> <tr> <td>RoHS</td> <td>Compliant</td> </tr> </table>		Environmental Data		Temperature range	-65°C to +165°C	Thermal shock	MIL-STD-202, Method107, Condition B	Moisture resistance	MIL-STD-202, Method106	Corrosion	MIL-STD-202, Method101, Condition B	RoHS	Compliant										
Environmental Data																							
Temperature range	-65°C to +165°C																						
Thermal shock	MIL-STD-202, Method107, Condition B																						
Moisture resistance	MIL-STD-202, Method106																						
Corrosion	MIL-STD-202, Method101, Condition B																						
RoHS	Compliant																						
<table border="1" style="width: 100%;"> <tr> <td style="width: 30%;">Tooling</td> <td></td> </tr> </table>		Tooling																					
Tooling																							

Notice: JYEBAO reserves the right to make modifications deemed appropriate.

JYE BAO CO., LTD.

CABLE ASSEMBLY RECOMMENDATION

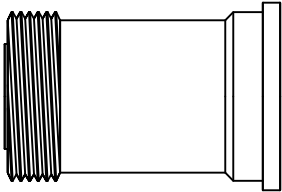
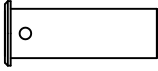
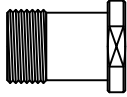
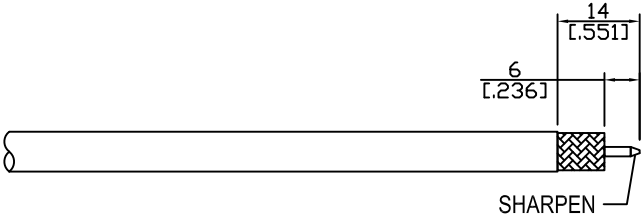
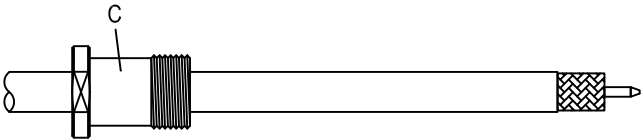
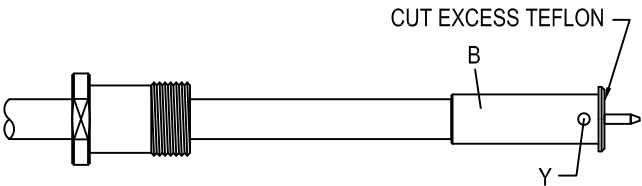
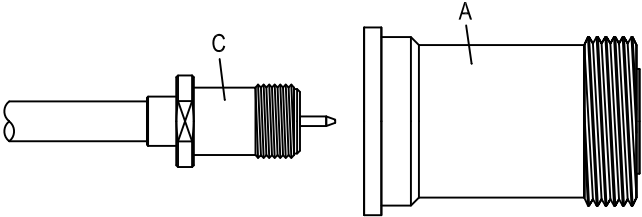
7/16-8346L-0250/FEP	DATE	2014/04/29	REV	—
A	B	C		
 <p style="text-align: center;">BODY</p>	 <p style="text-align: center;">SOLDER FERRULE</p>	 <p style="text-align: center;">NUT</p>		
DIAGRAM	ASSEMBLY INSTRUCTION			
	<p>Step 1: STRIP AS SHOWN. Step 2: SHARPEN CENTER CONDUCTOR TIP.</p>			
	<p>Step 3: SLIDE NUT " C " OVER CABLE.</p>			
	<p>Step 4: PUT FERRULE " B " ON CENTER CONDUCTOR AND SOLDER IN " Y ". Step 5: CUT AWAY ANY EXCESS TEFLON STICKING OUT OF THE SOLDER FERRULE.</p>			
	<p>Step 6: FINALLY SCREW NUT " C " ON THE CONNECTOR BODY " A ".</p>			
<p>This part number complies with RoHS. Notice: JYEBAO reserves the right to make modifications deemed appropriate.</p>				
APPROVED	CHECKED	DRAWING	<i>Albert</i>	

7/16-8346L-0250/FEP

S11

