

7/16-8346KA-0141

7/16 Jack Solder For Panel Receptacle

50Ω

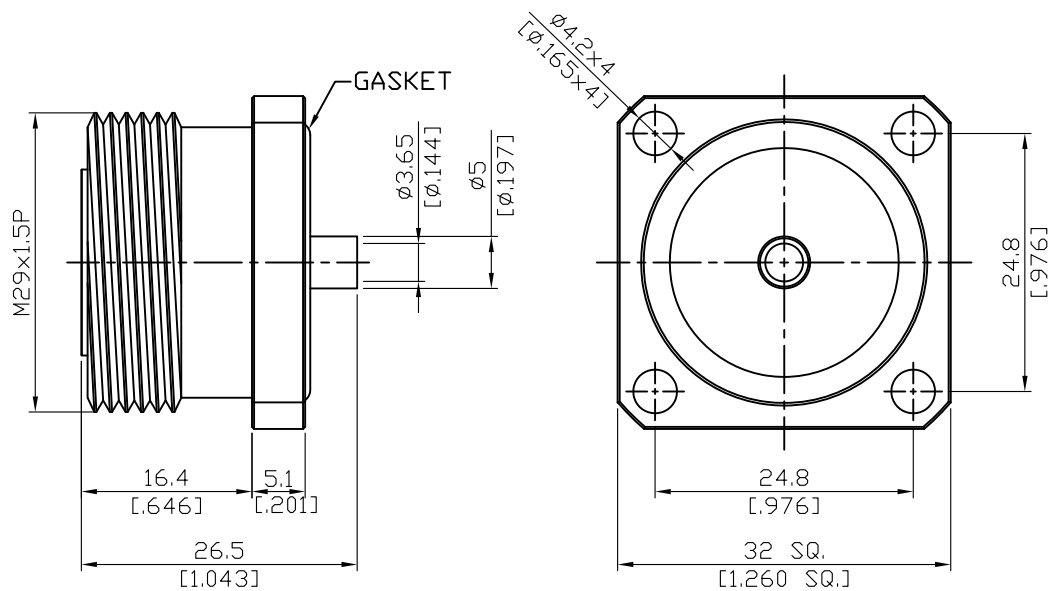

| Parts | Material | Plating (Micro-inch) |
|-------------|------------------|---|
| Body | Brass | Gold 4 Over Nickel-Phosphorus Alloy 80 Over Copper 20 |
| Insulator | Teflon | |
| Contact Pin | Beryllium Copper | Gold 4 Over Nickel-Phosphorus Alloy 80 Over Copper 20 |
| Gasket | Silicone | |

This part number complies with RoHS.

Notice: JYEBAO reserves the right to make modifications deemed appropriate.

JYE BAO CO., LTD.

CABLE ASSEMBLY INSTRUCTION

| | | | | |
|------------------|------|------------|-----|---|
| 7/16-8346KA-0141 | DATE | 2018/06/01 | REV | — |
|------------------|------|------------|-----|---|

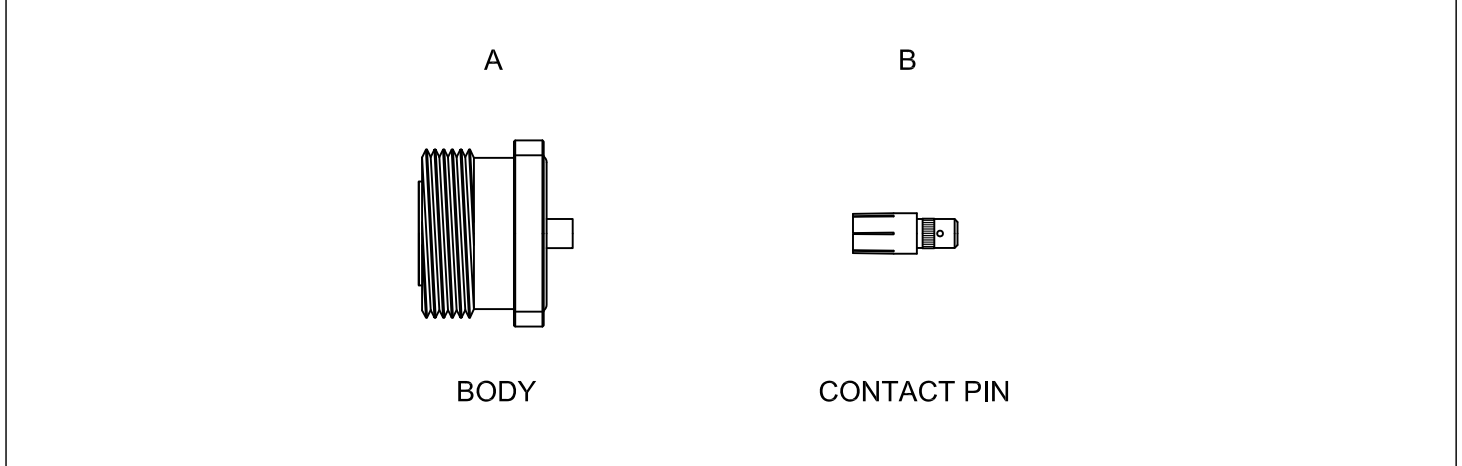

| DIAGRAM | ASSEMBLY INSTRUCTION |
|---------|----------------------|
|---------|----------------------|

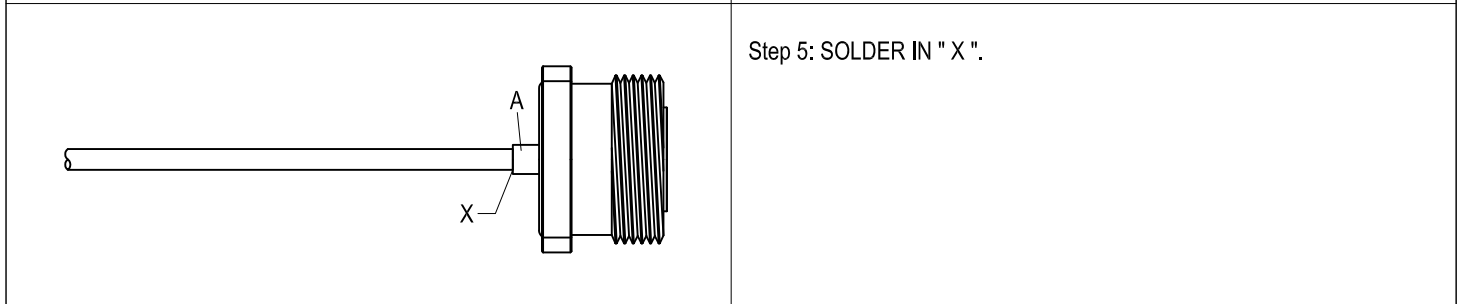
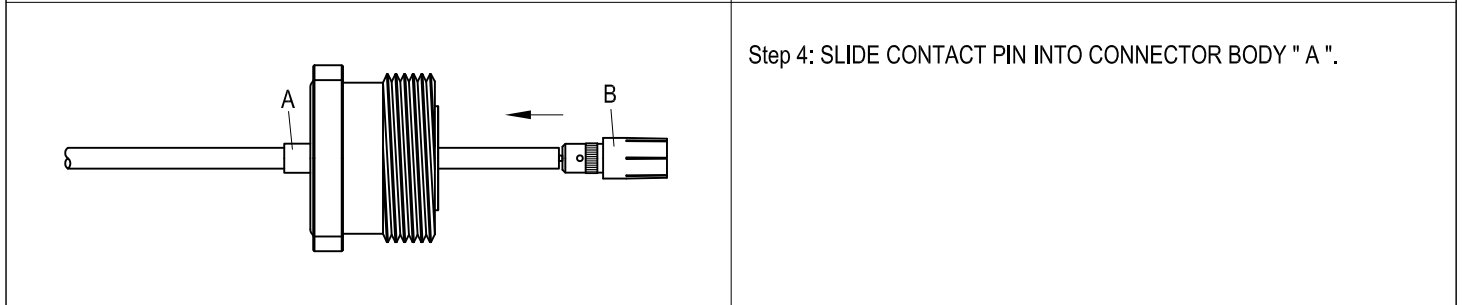
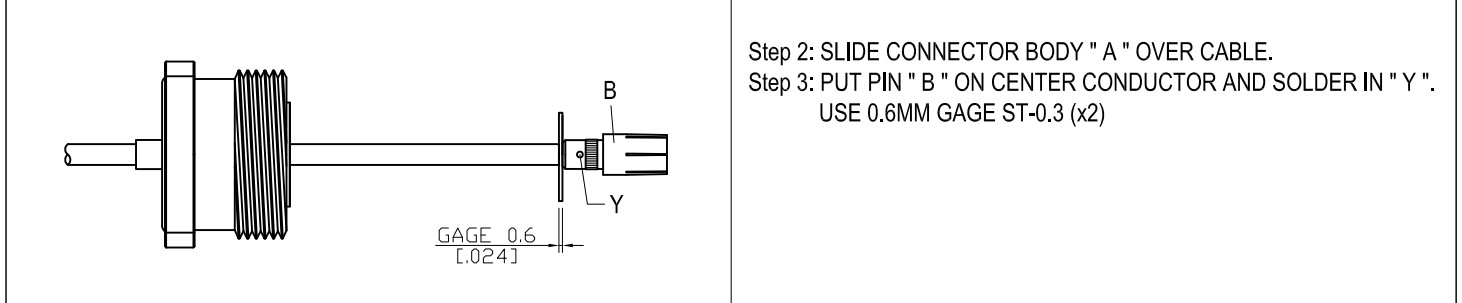
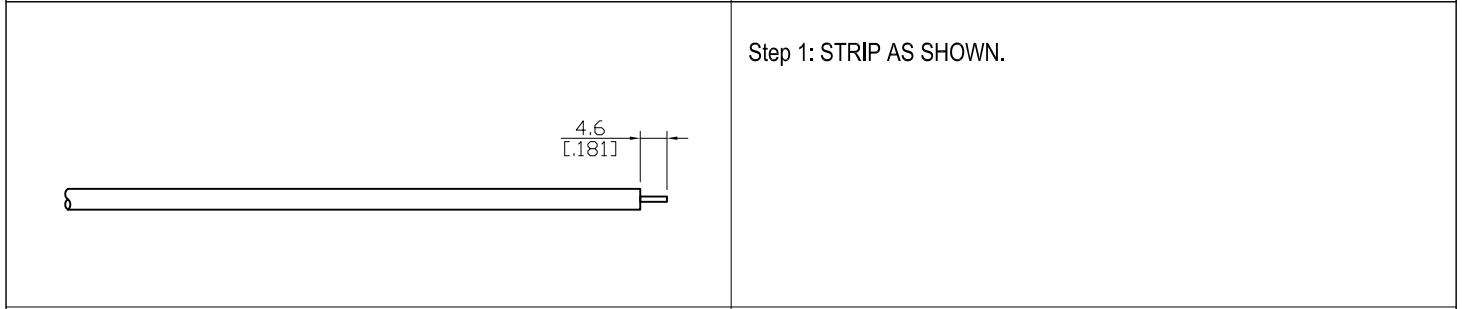

This part number complies with RoHS.
 Notice: JYEBAO reserves the right to make modifications deemed appropriate.

| | | |
|----------|---------|---------------|
| APPROVED | CHECKED | DRAWING |
| | | <i>Albert</i> |