

7/16-8305A-0250

7/16 Jack Solder For Bulkhead 50Ω

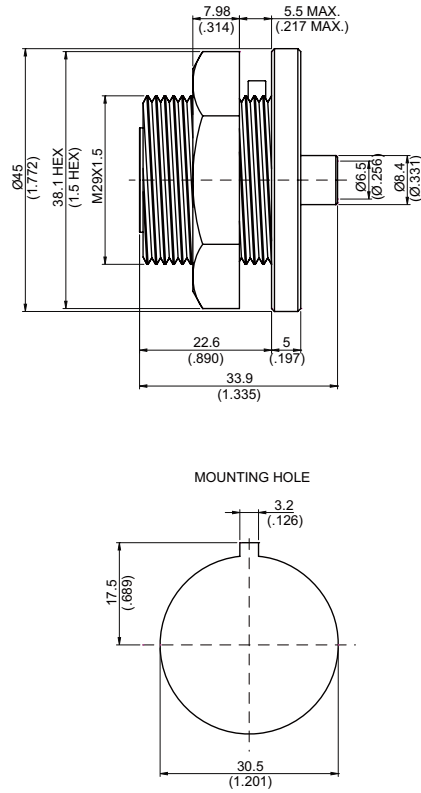

NOTE: Spring finger design ensure easy assembly

Parts	Material	Plating(Micro-inch)
Nut	Brass	Tin-Zinc-Copper-Alloy 100 Over Copper 50
Barrel	Brass	Tin-Zinc-Copper-Alloy 100 Over Copper 50
Contact Pin	Phosphor Bronze	Silver 150 Over Copper 50
Insulator	Teflon	
Body	Brass	Tin-Zinc-Copper-Alloy 100 Over Copper 50

Weight: 170.28 g

Suitable Cables: Semi-rigid.250

This part number complies with RoHS.

Notice: JYEBAO reserves the right to make modifications deemed appropriate.

## CABLE ASSEMBLY INSTRUCTION

7/16-8305A-0250

JYE BAO CO., LTD.

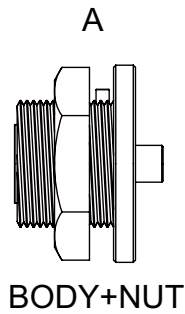

DIAGRAM	ASSEMBLY INSTRUCTION
	<p>Step 1: STRIP AS SHOWN .</p>
<p style="text-align: right;">SHARPEN</p>	<p>Step 2: SHARPEN CENTER CONDUCTOR TIP.</p>
	<p>Step 3: SLIDE CABLE INTO CONNECTOR BODY "A".</p>
	<p>Step 4: INSERT PREPARED CABLE INTO CONNECTOR BODY "A" AND SOLDER IN "Y".</p>

**This part number complies with RoHS.**

**Notice: JYEBAO reserves the right to make modifications deemed appropriate.**