

7/16-8305-0250 **7/16 Jack Solder For Bulkhead 50Ω**

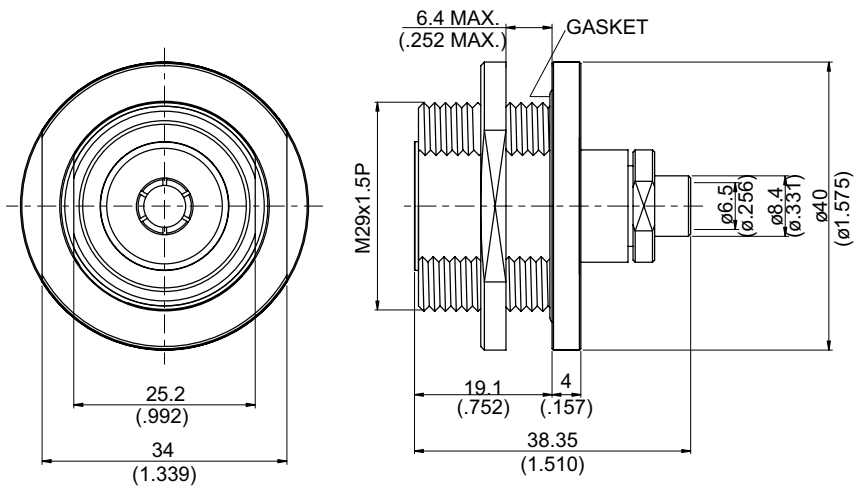

**MOUNTING HOLE**

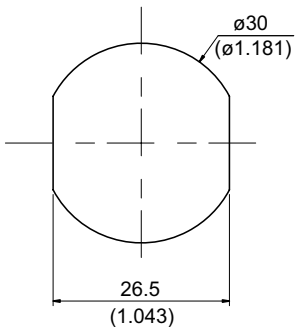

Parts	Material	Plating(Micro-inch)
Nut	Brass	Tin-Zinc-Copper-Alloy 100 Over Copper 50
Barrel	Brass	Tin-Zinc-Copper-Alloy 100 Over Copper 50
Solder Ferrule	Brass	Gold 5 Over Nickel 50 Over Copper 50
Body	Brass	Tin-Zinc-Copper-Alloy 100 Over Copper 50
Gasket	Silicon	
Contact Pin	Phosphor Bronze	Silver 150 Over Copper 50
Insulator	Teflon	

Weight: 189.7 g  
 Suitable Cables: Semi-rigid.250

**This part number complies with RoHS.**  
**Notice: JYEBAO reserves the right to make modifications deemed appropriate.**

## CABLE ASSEMBLY INSTRUCTION

7/16-8305-0250

JYE BAO CO., LTD.

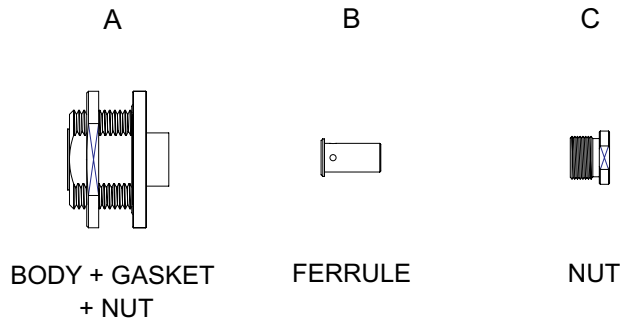
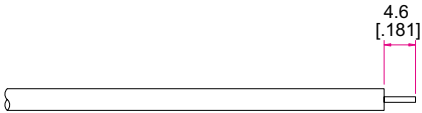
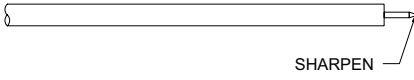
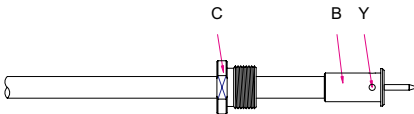
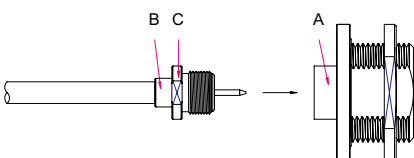

DIAGRAM	ASSEMBLY INSTRUCTION
	Step 1: STRIP AS SHOWN .
	Step 2: SHARPEN CENTER CONDUCTOR TIP.
	Step 3: SLIDE NUT " C " OVER CABLE . Step 4: PUT FERRULE " B " ON CENTER CONDUCTOR AND SOLDER IN " Y " . Step 5: STRIP EXCESS TEFLON AFTER SOLDERING .
	Step 6: FINALLY SCREW " C " ON THE CONNECTOR BODY " A ".

This part number complies with RoHS.

Notice: JYEBAO reserves the right to make modifications deemed appropriate.