

7/16-8305-0141

7/16 Jack Solder For Bulkhead 50Ω

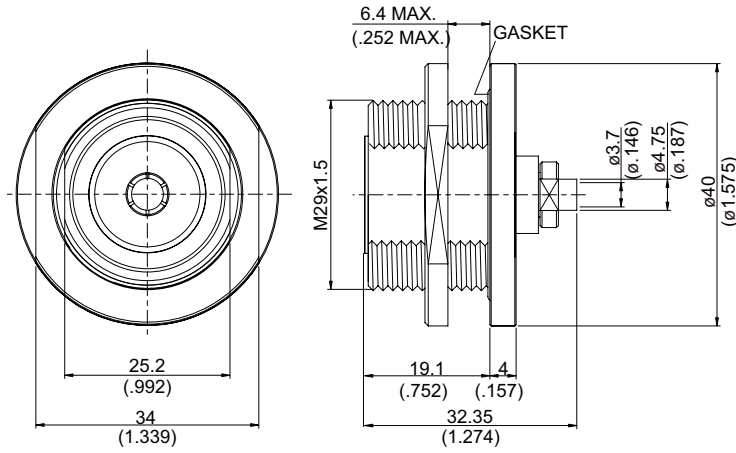

MOUNTING HOLE

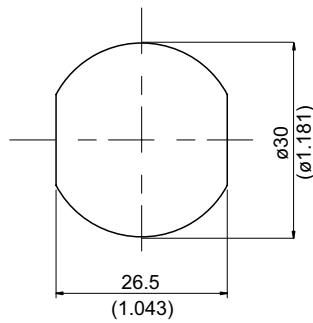

Parts	Material	Plating(Micro-inch)
Nut	Brass	Tin-Zinc-Copper-Alloy 100 Over Copper 50
Crimp Nut	Brass	Tin-Zinc-Copper-Alloy 100 Over Copper 50
Solder Ferrule	Brass	Gold 5 Over Nickel 50 Over Copper 50
Barrel	Brass	Tin-Zinc-Copper-Alloy 100 Over Copper 50
Body	Brass	Tin-Zinc-Copper-Alloy 100 Over Copper 50
Gasket	Silicon	
Contact Pin	Phosphor Bronze	Silver 150 Over Copper 50
Insulator	Teflon	

Weight: 105.69 g
Suitable Cables: Semi-rigid.141

This part number complies with RoHS.

Notice: JYEBAO reserves the right to make modifications deemed appropriate.

CABLE ASSEMBLY INSTRUCTION

7/16-8305-0141

JYE BAO CO., LTD.

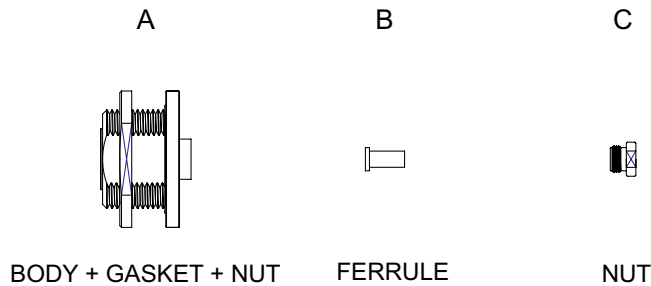

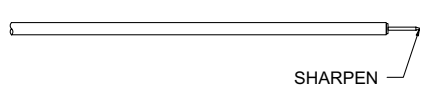

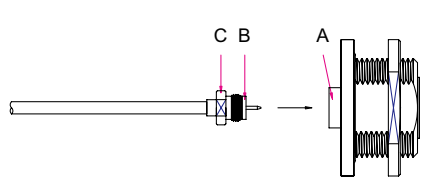

DIAGRAM	ASSEMBLY INSTRUCTION
	Step 1: STRIP AS SHOWN .
 <p style="text-align: right;">SHARPEN</p>	Step 2: SHARPEN CENTER CONDUCTOR TIP.
	Step 3: SLIDE FERRULE " B " AND NUT " C " OVER CABLE AND SOLDER IN " Y " . Step 4: STRIP EXCESS TEFLON AFTER SOLDERING .
	Step 5: FINALLY SCREW " C " ON THE CONNECTOR BODY " A " .

This part number complies with RoHS.

Notice: JYEBAO reserves the right to make modifications deemed appropriate.