

7/16-8246-8DFB

7/16 Jack Clamp For Panel Receptacle 50Ω

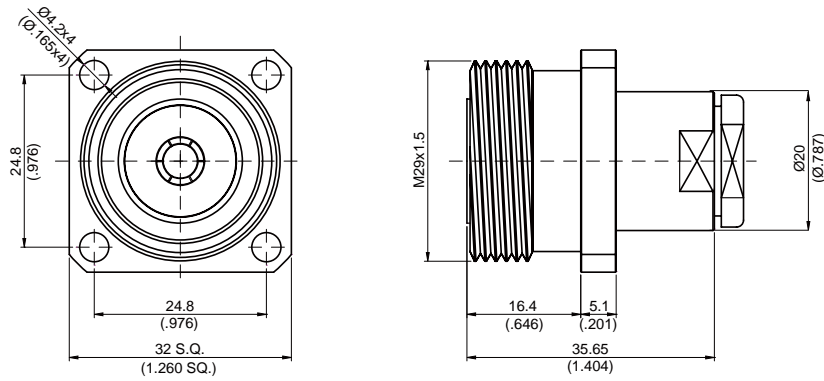

**MOUNTING HOLE**

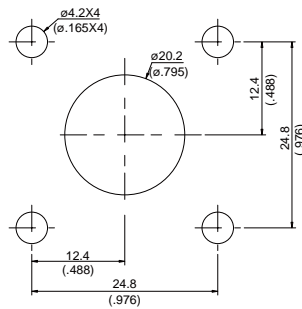

NOTE: Spring finger design ensures easy assembly.

Parts	Material	Plating(Micro-inch)
Nut	Brass	Tin-Zinc-Copper-Alloy 100 Over Copper 50
Washer	Brass	Tin-Zinc-Copper-Alloy 100 Over Copper 50
Gasket	Silicon	
Braid Clamp	Brass	Tin-Zinc-Copper-Alloy 100 Over Copper 50
Barrel	Brass	Tin-Zinc-Copper-Alloy 100 Over Copper 50
Contact Pin	Phosphor Bronze	Silver 150 Over Copper 50
Insulator	Teflon	
Body	Brass	Tin-Zinc-Copper-Alloy 100 Over Copper 50

Weight:  
Suitable Cables: 8DFB, JBY300

This part number complies with RoHS.

Notice: JYEBAC reserves the right to make modifications deemed appropriate.

# JYE BAO CO., LTD.

## CABLE ASSEMBLY INSTRUCTION







7/16-8246-8DFB		DATE	2018/06/01	REV	—
A	B	C	D	E	F
					
BODY	WASHER	BRAID CLAMP	GASKET	WASHER	NUT

DIAGRAM	ASSEMBLY INSTRUCTION
	Step 1: STRIP AS SHOWN.
	Step 2: SLIDE NUT " F " 、 WASHER " E " 、 GASKET " D " AND BRAID CLAMP " C " OVER CABLE.
	Step 3: WRAP THE BRAIDING OVER " C ".
	Step 4: STRIP AS SHOWN.
	Step 5: SHARPEN CENTER CONDUCTOR TIP. Step 6: SLIDE WASHER " B " IN PLACE.
	Step 7: FINALLY SCREW NUT " F " ON THE CONNECTOR BODY " A ".

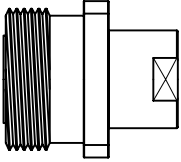
This part number complies with RoHS.

Notice: JYEBAO reserves the right to make modifications deemed appropriate.

APPROVED

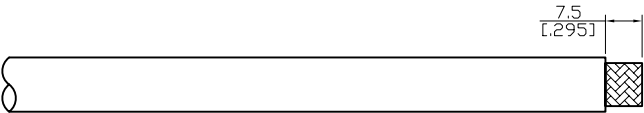
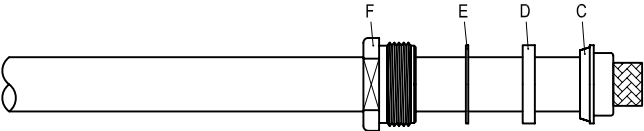
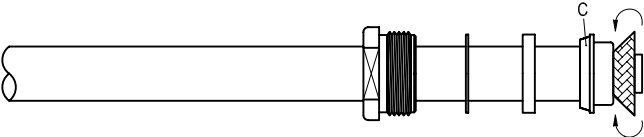
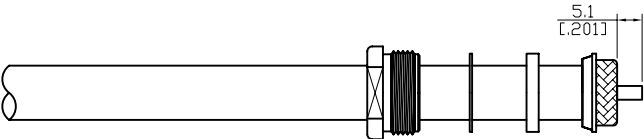
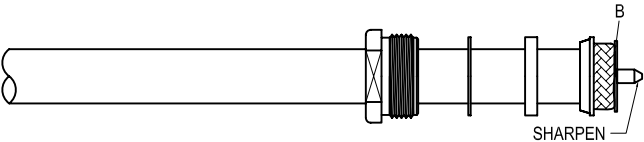
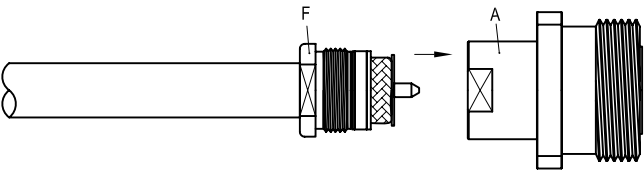
CHECKED

DRAWING

*Albert*