

**7/16-8246-0142 7/16 Jack Clamp 4 Hole Flange For RG58,RG142, 50Ω
RG400,JBY195,LMR195; 3GHz VSWR 1.2**

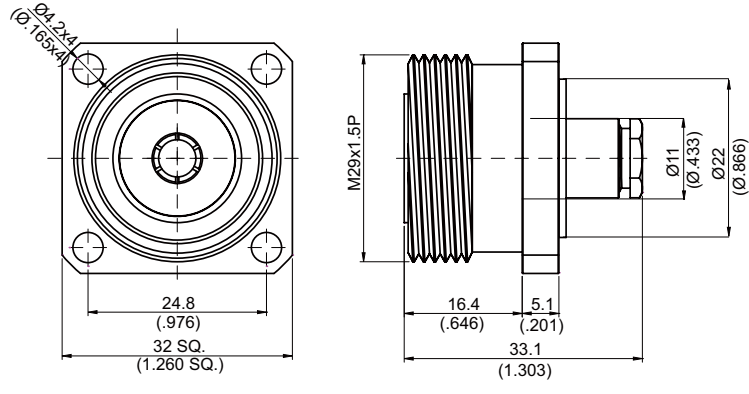

MOUNTING HOLE

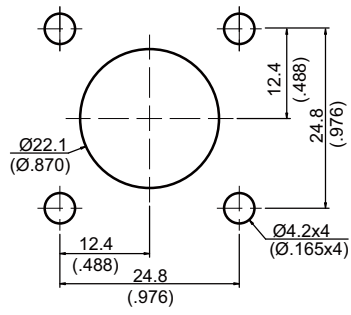

Parts	Material	Plating(Micro-inch)
Nut	Brass	Tin-Zinc-Copper-Alloy 100 Over Copper 50
Washer	Brass	Tin-Zinc-Copper-Alloy 100 Over Copper 50
Gasket	Silicon	
Top Hat	Brass	Tin-Zinc-Copper-Alloy 100 Over Copper 50
Barrel	Brass	Tin-Zinc-Copper-Alloy 100 Over Copper 50
Contact Pin	Phosphor Bronze	Silver 150 Over Copper 50
Insulator	Teflon	
Body	Brass	Tin-Zinc-Copper-Alloy 100 Over Copper 50

Weight: 87.42 g
Suitable Cables: RG55,RG142,RG400,RG58,JBY195

This part number complies with RoHS.
Notice: JYEBAO reserves the right to make modifications deemed appropriate.

7/16	7/16-8246-0142																				
<div style="border: 1px solid black; padding: 2px; margin-bottom: 5px;">Interface</div> <p>IEC 60169-4</p>																					
<div style="border: 1px solid black; padding: 2px; margin-bottom: 5px;">Electrical Data</div> <table style="width: 100%; border-collapse: collapse;"> <tr> <td style="width: 60%;">Impedance</td> <td style="text-align: right;">50Ω</td> </tr> <tr> <td>Frequency range</td> <td style="text-align: right;">DC to 3GHz</td> </tr> <tr> <td>VSWR</td> <td style="text-align: right;">≤ 1.2 (DC to 3GHz)</td> </tr> <tr> <td>Insertion loss</td> <td style="text-align: right;">≤ 0.05dB</td> </tr> <tr> <td>Insulation resistance</td> <td style="text-align: right;">≥ 10000MΩ</td> </tr> <tr> <td>Contact resistance inner conductor</td> <td style="text-align: right;">≤ 0.4mΩ</td> </tr> <tr> <td>Contact resistance outer conductor</td> <td style="text-align: right;">≤ 1.5mΩ</td> </tr> <tr> <td>Dielectric withstanding voltage (at sea level)</td> <td style="text-align: right;">4000 V rms</td> </tr> <tr> <td>Working Voltage (at sea level)</td> <td style="text-align: right;">2700 V rms</td> </tr> <tr> <td>RF leakage</td> <td style="text-align: right;">≥ 128dB to 1GHz</td> </tr> </table>		Impedance	50Ω	Frequency range	DC to 3GHz	VSWR	≤ 1.2 (DC to 3GHz)	Insertion loss	≤ 0.05dB	Insulation resistance	≥ 10000MΩ	Contact resistance inner conductor	≤ 0.4mΩ	Contact resistance outer conductor	≤ 1.5mΩ	Dielectric withstanding voltage (at sea level)	4000 V rms	Working Voltage (at sea level)	2700 V rms	RF leakage	≥ 128dB to 1GHz
Impedance	50Ω																				
Frequency range	DC to 3GHz																				
VSWR	≤ 1.2 (DC to 3GHz)																				
Insertion loss	≤ 0.05dB																				
Insulation resistance	≥ 10000MΩ																				
Contact resistance inner conductor	≤ 0.4mΩ																				
Contact resistance outer conductor	≤ 1.5mΩ																				
Dielectric withstanding voltage (at sea level)	4000 V rms																				
Working Voltage (at sea level)	2700 V rms																				
RF leakage	≥ 128dB to 1GHz																				
<div style="border: 1px solid black; padding: 2px; margin-bottom: 5px;">Mechanical Data</div> <table style="width: 100%; border-collapse: collapse;"> <tr> <td style="width: 60%;">Recommended coupling nut torque</td> <td style="text-align: right;">260 inch lbs</td> </tr> <tr> <td>Coupling proof torque</td> <td style="text-align: right;">310 inch lbs</td> </tr> <tr> <td>Contact captivation-axial</td> <td style="text-align: right;">≥ 45 lbs</td> </tr> <tr> <td>Durability (mating)</td> <td style="text-align: right;">≥ 500</td> </tr> </table>		Recommended coupling nut torque	260 inch lbs	Coupling proof torque	310 inch lbs	Contact captivation-axial	≥ 45 lbs	Durability (mating)	≥ 500												
Recommended coupling nut torque	260 inch lbs																				
Coupling proof torque	310 inch lbs																				
Contact captivation-axial	≥ 45 lbs																				
Durability (mating)	≥ 500																				
<div style="border: 1px solid black; padding: 2px; margin-bottom: 5px;">Environmental Data</div> <table style="width: 100%; border-collapse: collapse;"> <tr> <td style="width: 60%;">Temperature range</td> <td style="text-align: right;">-65°C to +165°C</td> </tr> <tr> <td>Thermal shock</td> <td style="text-align: right;">MIL-STD-202, Method107, Condition B</td> </tr> <tr> <td>Moisture resistance</td> <td style="text-align: right;">MIL-STD-202, Method106</td> </tr> <tr> <td>Corrosion</td> <td style="text-align: right;">MIL-STD-202, Method101, Condition B</td> </tr> <tr> <td>RoHS</td> <td style="text-align: right;">Compliant</td> </tr> </table>		Temperature range	-65°C to +165°C	Thermal shock	MIL-STD-202, Method107, Condition B	Moisture resistance	MIL-STD-202, Method106	Corrosion	MIL-STD-202, Method101, Condition B	RoHS	Compliant										
Temperature range	-65°C to +165°C																				
Thermal shock	MIL-STD-202, Method107, Condition B																				
Moisture resistance	MIL-STD-202, Method106																				
Corrosion	MIL-STD-202, Method101, Condition B																				
RoHS	Compliant																				
<div style="border: 1px solid black; padding: 2px; margin-bottom: 5px;">Tooling</div>																					

Notice: JYEBAO reserves the right to make modifications deemed appropriate.

JYE BAO CO., LTD.

CABLE ASSEMBLY INSTRUCTION

7/16-8246-0142	DATE	2016/01/15	REV	—
----------------	------	------------	-----	---





A	B	C	D	E
				
BODY	TOP HAT	GASKET	WASHER	NUT

DIAGRAM	ASSEMBLY INSTRUCTION
---------	----------------------

	<p>Step 1: STRIP AS SHOWN.</p>
---	--------------------------------

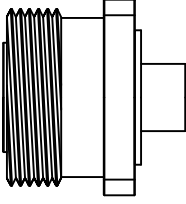
	<p>Step 2: SLIDE NUT " E " 、 WASHER " D " 、 GASKET " C " AND TOP HAT " B " OVER CABLE.</p>
---	--

	<p>Step 3: WRAP THE BRAIDING OVER " B ".</p>
---	--

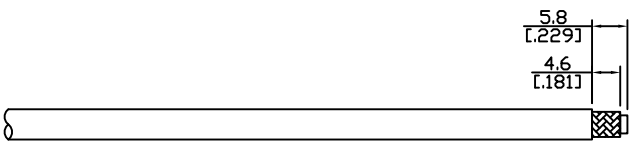
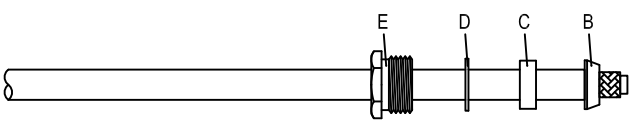
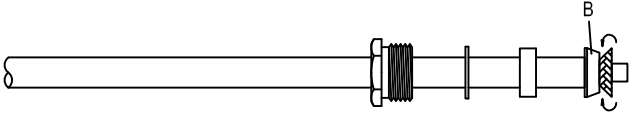
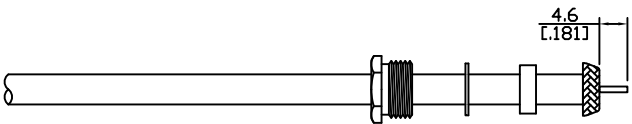
	<p>Step 4: STRIP AS SHOWN.</p>
---	--------------------------------

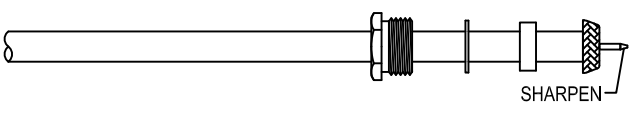
	<p>Step 5: SHARPEN CENTER CONDUCTOR TIP.</p>
---	--

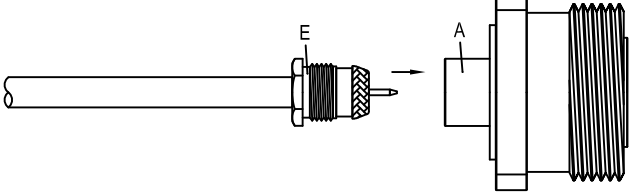
	<p>Step 6: FINALLY SCREW NUT " E " ON THE CONNECTOR BODY " A ".</p>
---	---

This part number complies with RoHS.

Notice: JYEBAO reserves the right to make modifications deemed appropriate.

APPROVED	CHECKED	DRAWING
		<i>Albert</i>

7/16-8246-0142

S11

