

7/16-8146A-0214

7/16 jack crimp 32mm SQ 4 hole flange
For RG214; 2.5GHz VSWR 1.2

50Ω

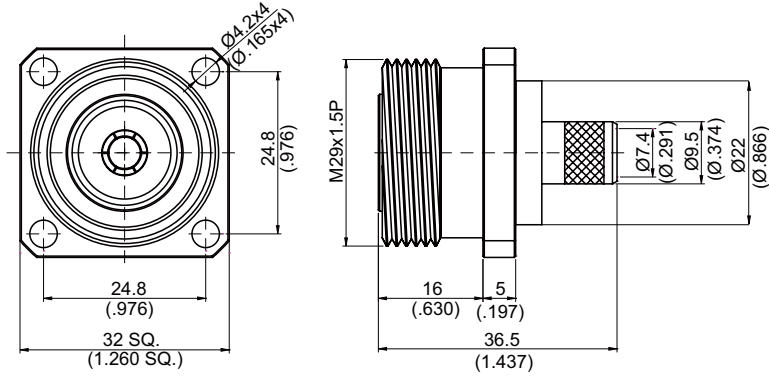

MOUNTING HOLE

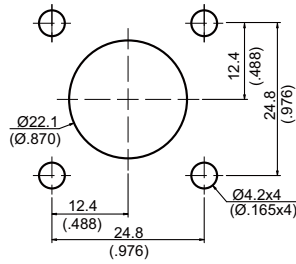

NOTE: Comes With PVC Dust Cap

Parts	Material	Plating(Micro-inch)
Ferrule	Brass	Tin-Zinc-Copper-Alloy 100 Over Copper 50
Small Pin	Brass	Gold 4 Over Nickel-Phosphorus Alloy 80 Over Copper 20
Barrel	Brass	Tin-Zinc-Copper-Alloy 100 Over Copper 50
Contact Pin	Beryllium Copper	Gold 4 Over Nickel-Phosphorus Alloy 80 Over Copper 20
Insulator	Teflon	
Body	Brass	Tin-Zinc-Copper-Alloy 100 Over Copper 50

Suitable Cables: RG214

This part number complies with RoHS.

Notice: JYEBAO reserves the right to make modifications deemed appropriate.

7/16	7/16-8146A-0214																						
<table border="1"> <tr> <td colspan="2">Interface</td> </tr> <tr> <td colspan="2">IEC 60169-4</td> </tr> </table>		Interface		IEC 60169-4																			
Interface																							
IEC 60169-4																							
<table border="1"> <tr> <td colspan="2">Electrical Data</td> </tr> <tr> <td>Impedance</td> <td>50Ω</td> </tr> <tr> <td>Frequency range</td> <td>DC to 2.5GHz</td> </tr> <tr> <td>VSWR</td> <td>≦ 1.2 (DC to 2.5GHz)</td> </tr> <tr> <td>Insertion loss</td> <td>≦ 0.05dB</td> </tr> <tr> <td>Insulation resistance</td> <td>≧ 10000MΩ</td> </tr> <tr> <td>Contact resistance inner conductor</td> <td>≦ 0.4mΩ</td> </tr> <tr> <td>Contact resistance outer conductor</td> <td>≦ 1.5mΩ</td> </tr> <tr> <td>Dielectric withstanding voltage (at sea level)</td> <td>4000 V rms</td> </tr> <tr> <td>Working Voltage (at sea level)</td> <td>2700 V rms</td> </tr> <tr> <td>RF leakage</td> <td>≧ 128dB to 1GHz</td> </tr> </table>		Electrical Data		Impedance	50Ω	Frequency range	DC to 2.5GHz	VSWR	≦ 1.2 (DC to 2.5GHz)	Insertion loss	≦ 0.05dB	Insulation resistance	≧ 10000MΩ	Contact resistance inner conductor	≦ 0.4mΩ	Contact resistance outer conductor	≦ 1.5mΩ	Dielectric withstanding voltage (at sea level)	4000 V rms	Working Voltage (at sea level)	2700 V rms	RF leakage	≧ 128dB to 1GHz
Electrical Data																							
Impedance	50Ω																						
Frequency range	DC to 2.5GHz																						
VSWR	≦ 1.2 (DC to 2.5GHz)																						
Insertion loss	≦ 0.05dB																						
Insulation resistance	≧ 10000MΩ																						
Contact resistance inner conductor	≦ 0.4mΩ																						
Contact resistance outer conductor	≦ 1.5mΩ																						
Dielectric withstanding voltage (at sea level)	4000 V rms																						
Working Voltage (at sea level)	2700 V rms																						
RF leakage	≧ 128dB to 1GHz																						
<table border="1"> <tr> <td colspan="2">Mechanical Data</td> </tr> <tr> <td>Recommended coupling nut torque</td> <td>260 inch lbs</td> </tr> <tr> <td>Coupling proof torque</td> <td>310 inch lbs</td> </tr> <tr> <td>Contact captivation-axial</td> <td>≧ 45 lbs</td> </tr> <tr> <td>Durability (mating)</td> <td>≧ 500</td> </tr> </table>		Mechanical Data		Recommended coupling nut torque	260 inch lbs	Coupling proof torque	310 inch lbs	Contact captivation-axial	≧ 45 lbs	Durability (mating)	≧ 500												
Mechanical Data																							
Recommended coupling nut torque	260 inch lbs																						
Coupling proof torque	310 inch lbs																						
Contact captivation-axial	≧ 45 lbs																						
Durability (mating)	≧ 500																						
<table border="1"> <tr> <td colspan="2">Environmental Data</td> </tr> <tr> <td>Temperature range</td> <td>-65°C to +165°C</td> </tr> <tr> <td>Thermal shock</td> <td>MIL-STD-202, Method107, Condition B</td> </tr> <tr> <td>Moisture resistance</td> <td>MIL-STD-202, Method106</td> </tr> <tr> <td>Corrosion</td> <td>MIL-STD-202, Method101, Condition B</td> </tr> <tr> <td>RoHS</td> <td>Compliant</td> </tr> </table>		Environmental Data		Temperature range	-65°C to +165°C	Thermal shock	MIL-STD-202, Method107, Condition B	Moisture resistance	MIL-STD-202, Method106	Corrosion	MIL-STD-202, Method101, Condition B	RoHS	Compliant										
Environmental Data																							
Temperature range	-65°C to +165°C																						
Thermal shock	MIL-STD-202, Method107, Condition B																						
Moisture resistance	MIL-STD-202, Method106																						
Corrosion	MIL-STD-202, Method101, Condition B																						
RoHS	Compliant																						
<table border="1"> <tr> <td colspan="2">Tooling</td> </tr> <tr> <td>Crimping tool</td> <td>CRT-1 or CRT-2</td> </tr> <tr> <td>Crimp insert</td> <td>INSERT-C</td> </tr> </table>		Tooling		Crimping tool	CRT-1 or CRT-2	Crimp insert	INSERT-C																
Tooling																							
Crimping tool	CRT-1 or CRT-2																						
Crimp insert	INSERT-C																						

Notice: JYEBAO reserves the right to make modifications deemed appropriate.

JYE BAO CO., LTD.

CABLE ASSEMBLY INSTRUCTION

7/16-8146A-0214	DATE	2017/03/27	REV	—
-----------------	------	------------	-----	---

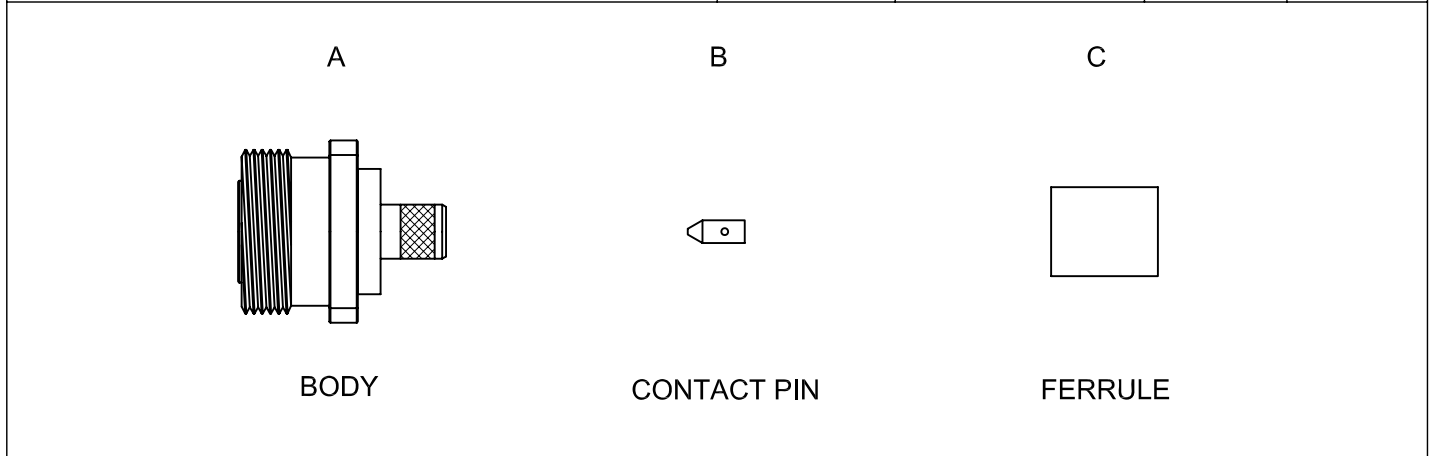
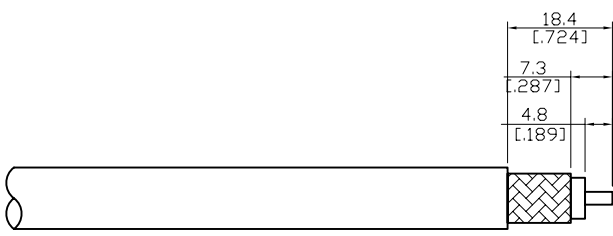
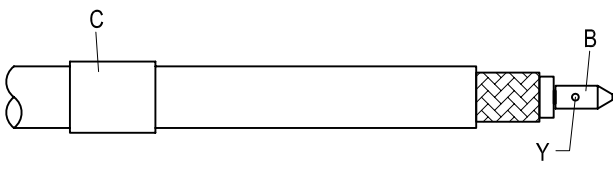
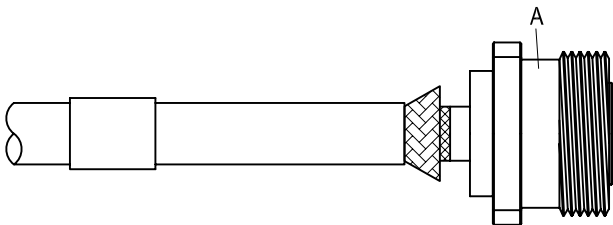
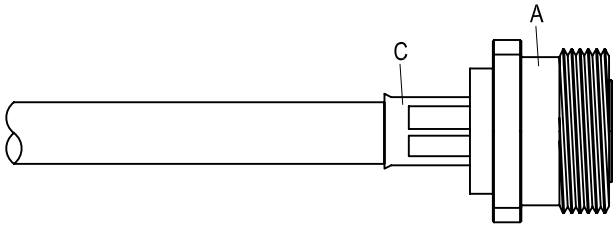

DIAGRAM	ASSEMBLY INSTRUCTION
---------	----------------------

	<p>Step 1: STRIP AS SHOWN.</p>
--	--------------------------------

	<p>Step 2: SLIDE FERRULE " C " OVER CABLE. Step 3: PUT PIN " B " ON CENTER CONDUCTOR AND SOLDER OR CRIMP IN " Y ". (USE 3.3mm/0.130inch HEX SECTION OF INSERT-C IF CRIMPED)</p>
---	---

	<p>Step 4: LOOSEN BRAIDING AND SLIDE CONNECTOR " A " IN PLACE.</p>
---	--

	<p>Step 5: SLIDE FERRULE " C " TOWARDS THE CONNECTOR " A " AND CRIMP. (USE 10.7mm/0.421inch HEX SECTION OF INSERT-C)</p>
---	---

This part number complies with RoHS.

Notice: JYEBAO reserves the right to make modifications deemed appropriate.

APPROVED	CHECKED	DRAWING
----------	---------	---------

Albert

7/16-8146A-0214

S11

