

7/16-8105-L400

7/16 Jack Crimp For Bulkhead

50Ω

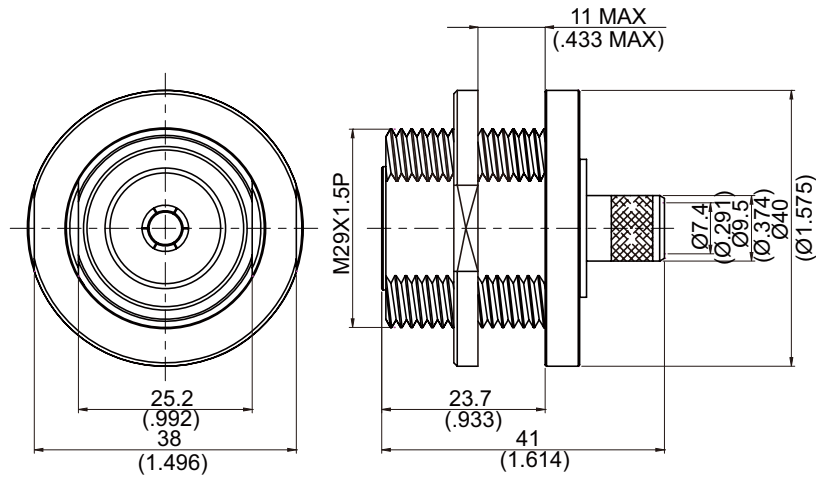

MOUNTING HOLE

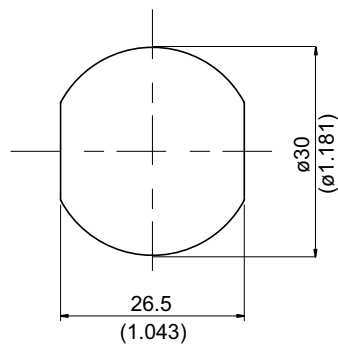

Parts	Material	Plating(Micro-inch)
Nut	Brass	Tin-Zinc-Copper-Alloy 100 Over Copper 50
Ferrule	Brass	Tin-Zinc-Copper-Alloy 100 Over Copper 50
Small Pin	Brass	Silver 100 Over Copper 50
Barrel	Brass	Tin-Zinc-Copper-Alloy 100 Over Copper 50
Contact Pin	Phosphor Bronze	Silver 100 Over Copper 50
Insulator	Teflon	
Body	Brass	Tin-Zinc-Copper-Alloy 100 Over Copper 50

Weight:
Suitable Cables: JBY400

This part number complies with RoHS.

Notice: JYEBAO reserves the right to make modifications deemed appropriate.

CABLE ASSEMBLY INSTRUCTION

7/16-8105-L400

JYE BAO CO., LTD.
TAIPEI TAIWAN R.O.C

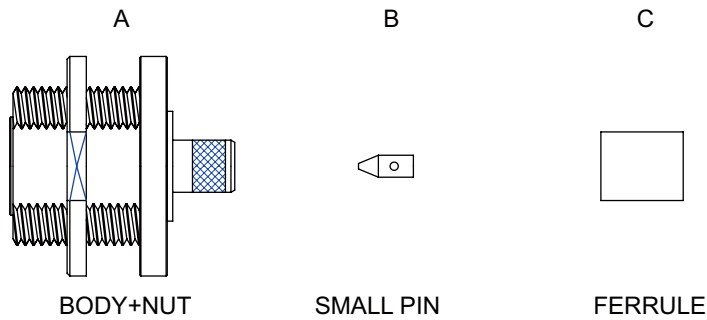

DIAGRAM	ASSEMBLY INSTRUCTION
	<p>Step 1: STRIP AS SHOWN.</p>
	<p>Step 2: SLIDE FERRULE " C " OVER CABLE. Step 3: PUT PIN " B " ON CENTER CONDUCTOR AND SOLDER IN " Y ".</p>
	<p>Step 4: LOOSEN BRAIDING AND SLIDE CONNECTOR " A " IN PLACE.</p>
	<p>Step 5: SLIDE FERRULE " C " TOWARDS THE CONNECTOR " A " AND CRIMP.</p>

This part number complies with RoHS.

Notice: JYBAO reserves the right to make modifications deemed appropriate.